

## Service Bulletin #168 SJ12E, SJ16E, SJ20E

### Mast Weld Reinforcement

\*\*\*\*\* ⚠ **SAFETY RELATED** ⚠ \*\*\*\*\*

A failure to comply with this bulletin could result in serious injury or death.

June, 16 2023

**Models Affected:** SJ12E, SJ16E, SJ20E

**Serial Ranges:**

SJ12E: A601000906 through A601005185

SJ16E: A601000909 through A601005478

SJ20E: A601000763 through A601005631

Specific Affected Serial Numbers are listed at the end of this bulletin.

#### **Introduction:**

On the identified machines, Skyjack has identified a quality issue with the weld between the mast base plate and mast vertical section. Failure to implement this bulletin may result in cracks developing along the weld between the mast base plate and the mast vertical section, potentially leading to structural failure of the vertical mast causing serious injury or death.

The units listed under “Affected Serial Numbers” **must be immediately removed from service** and have the mast section repaired as soon as possible. Skyjack requires that this bulletin be completed on all affected models with the listed serial numbers.

This bulletin is also available on our website at: [www.skyjack.com](http://www.skyjack.com).



**Procedure:**

All affected units must be immediately removed from service and have the repair completed before returning the unit to service. All units listed under “Affected Serial Numbers” must be repaired as specified in the attached Mast Weld Reinforcement Procedure (Skyjack part no. 248194). Only qualified and authorized personnel shall be permitted to service a Mobile Elevating Work Platform (MEWP), and all welding must be done by a welder qualified for Manual metal arc welding (MMA or MMAW) or shielded metal arc welding (SMAW) steel in a horizontal welding position for fillet welds (FW).

Contact Skyjack Service at the details below with any questions regarding the completion of this bulletin.

**Parts and Warranty Policy:**

For the repair procedure to be performed, Skyjack will reimburse up to 5 hours of labor per machine to complete the repair procedure.

Upon completion of this service bulletin, submit a warranty claim form for each machine stating that Service Bulletin #168 has been completed.

**Ownership of Machines:**

Skyjack requires that you promptly notify us of a new owner’s contact information if you have sold or transferred any machine. In particular, if you have sold or transferred a machine(s) with the serial numbers listed above, it is required that you promptly notify Skyjack of the new owner’s contact information. This service bulletin must also be forwarded to the new machine owner.

**Contact Information:**

We regret any inconvenience and appreciate your cooperation. If you have any questions please call Skyjack;

- North America: **+1-800-275-9522**
- Europe & Middle East: **+44-1691-676-235**
- Australia & Asia: **+61 (0) 29854 0700**

You may e-mail any questions to [service@skyjack.com](mailto:service@skyjack.com).



**Affected Serial Numbers:**

**AS: SJ12E**

A601000907, A601001187, A601001188, A601001189, A601001190, A601003651,  
A601003653, A601003654, A601003656, A601003657, A601003659, A601003660,  
A601003662, A601003741, A601003742, A601003904, A601003906, A601003908,  
A601003909, A601003911

**AS: SJ16E**

A601001228, A601001230, A601001232, A601001233, A601001235, A601001236,  
A601001238, A601001240, A601001839, A601001841, A601001851, A601001852,  
A601001858, A601001860, A601001884, A601001886, A601001892, A601001893,  
A601001899, A601001901, A601001933, A601001937, A601002011, A601002513,  
A601002514, A601002544, A601002545, A601002578, A601002639, A601002848,  
A601002851, A601002854, A601002856, A601002859, A601002934, A601002935,  
A601002937, A601003018, A601003019, A601003020, A601003022, A601003023,  
A601003025, A601003491, A601003492, A601003493, A601003494, A601003495,  
A601003496, A601003497, A601003498, A601003499, A601003500, A601003510,  
A601003645, A601003646, A601003648, A601003649, A601003650, A601003664,  
A601003665, A601003667, A601003668, A601003670, A601003671, A601003673,  
A601003674, A601003676, A601003677, A601003679, A601003680, A601003682,  
A601003683, A601003685, A601003686, A601003688, A601003744, A601003745,  
A601003747, A601003749, A601003750, A601003752, A601003753, A601003755,  
A601003912, A601003914, A601003915, A601003917, A601003918, A601003920,  
A601003922, A601003923, A601003925, A601003926, A601003928, A601003956,  
A601003958, A601003960, A601003962, A601003963, A601004243, A601004245,  
A601004247, A601004249

**AS: SJ20E**

A601004933, A601004934, A601004935, A601004936, A601004937, A601004938,  
A601004941, A601004942, A601004943, A601004944, A601004945, A601004946,  
A601004949, A601004950, A601004951, A601004952, A601004953



**CE: SJ12E**

A601000906, A601000934, A601000940, A601000949, A601000968, A601000974,  
A601000984, A601000990, A601000999, A601001003, A601001004, A601001005,  
A601001006, A601001007, A601001008, A601001009, A601001010, A601001022,  
A601001028, A601001038, A601001042, A601001043, A601001044, A601001045,  
A601001046, A601001047, A601001048, A601001049, A601001050, A601001051,  
A601001052, A601001053, A601001054, A601001055, A601001056, A601001057,  
A601001058, A601001059, A601001060, A601001061, A601001062, A601001063,  
A601001064, A601001065, A601001066, A601001067, A601001068, A601001069,  
A601001070, A601001071, A601001072, A601001073, A601001074, A601001075,  
A601001076, A601001129, A601001130, A601001136, A601001137, A601001140,  
A601001141, A601001142, A601001143, A601001144, A601001167, A601001168,  
A601001174, A601001175, A601001180, A601001181, A601001191, A601001192,  
A601001194, A601001196, A601001197, A601001276, A601001277, A601001279,  
A601001280, A601001282, A601001283, A601001285, A601001286, A601001310,  
A601001311, A601001313, A601001314, A601001316, A601001317, A601001319,  
A601001321, A601001322, A601001324, A601001325, A601001433, A601001435,  
A601001437, A601001438, A601001439, A601001440, A601001441, A601001442,  
A601001443, A601001444, A601001445, A601001446, A601001468, A601001469,  
A601001470, A601001471, A601001472, A601001473, A601001474, A601001475,  
A601001476, A601001477, A601001478, A601001479, A601001480, A601001481,  
A601001482, A601001483, A601001484, A601001485, A601001486, A601001487,  
A601001488, A601001489, A601001770, A601001771, A601001772, A601001800,  
A601001866, A601001867, A601001987, A601002008, A601002017, A601002020,  
A601002051, A601002099, A601002102, A601002104, A601002107, A601002110,  
A601002112, A601002115, A601002117, A601002120, A601002122, A601002125,  
A601002126, A601002128, A601002659, A601002660, A601002661, A601002778,  
A601002788, A601002790, A601002793, A601002862, A601003251, A601003253,  
A601003255, A601003257, A601003259, A601003261, A601003263, A601003266,  
A601003295, A601003296, A601003297, A601003298, A601003299, A601003300,  
A601003301, A601003302, A601003303, A601003304, A601003305, A601003306,  
A601003371, A601003372, A601003373, A601003374, A601003375, A601003376,  
A601003377, A601003378, A601003379, A601003380, A601003381, A601003382,  
A601003383, A601003384, A601003385, A601003386, A601003387, A601003388,  
A601003389, A601003390, A601003391, A601003392, A601003393, A601003394,  
A601003395, A601003396, A601003397, A601003398, A601003399, A601003400,  
A601003401, A601003402, A601003403, A601003404, A601003405, A601003406,



A601003407, A601003408, A601003409, A601003470, A601003471, A601003472,  
A601003473, A601003474, A601003475, A601003476, A601003477, A601003478,  
A601003479, A601003480, A601003481, A601003482, A601003483, A601003484,  
A601003485, A601003486, A601003487, A601003488, A601003489, A601003490,  
A601003511, A601003512, A601003514, A601003515, A601003516, A601003518,  
A601003519, A601003521, A601003522, A601003523, A601003525, A601003526,  
A601003528, A601003529, A601003530, A601003532, A601003533, A601003535,  
A601003536, A601003537, A601003539, A601003540, A601003541, A601003543,  
A601003544, A601003546, A601003547, A601003548, A601003550, A601003577,  
A601003578, A601003580, A601003581, A601003582, A601003583, A601003584,  
A601003585, A601003586, A601003588, A601003589, A601003590, A601003591,  
A601003592, A601003593, A601003595, A601003596, A601003597, A601003598,  
A601003599, A601003600, A601003601, A601003603, A601003604, A601003605,  
A601003606, A601003607, A601003608, A601003610, A601003611, A601003612,  
A601003613, A601003614, A601003615, A601003616, A601003618, A601003619,  
A601003620, A601003621, A601003622, A601003623, A601003625, A601003626,  
A601003627, A601003628, A601003629, A601003630, A601003631, A601003633,  
A601003634, A601003635, A601003636, A601003637, A601003638, A601003640,  
A601003641, A601003642, A601003643, A601003644, A601003690, A601003691,  
A601003693, A601003694, A601003696, A601003697, A601003699, A601003700,  
A601003702, A601003703, A601003705, A601003706, A601003708, A601003726,  
A601003728, A601003729, A601003731, A601003733, A601003734, A601003736,  
A601003737, A601003739, A601004026, A601004027, A601004028, A601004030,  
A601004031, A601004032, A601004033, A601004034, A601004035, A601004036,  
A601004038, A601004039, A601004040, A601004041, A601004177, A601004179,  
A601004826, A601004827, A601004828, A601004829, A601004830, A601004831,  
A601004832

**CE: SJ16E**

A601000915, A601000928, A601000931, A601000961, A601001001, A601001002,  
A601001011, A601001012, A601001013, A601001014, A601001015, A601001016,  
A601001018, A601001020, A601001024, A601001026, A601001030, A601001032,  
A601001034, A601001036, A601001078, A601001079, A601001081, A601001082,  
A601001084, A601001085, A601001087, A601001088, A601001090, A601001091,  
A601001093, A601001094, A601001096, A601001097, A601001099, A601001100,  
A601001103, A601001104, A601001106, A601001107, A601001109, A601001110,  
A601001112, A601001113, A601001115, A601001116, A601001118, A601001119,  
A601001121, A601001122, A601001126, A601001127, A601001132, A601001133,



A601001139, A601001145, A601001146, A601001147, A601001148, A601001149,  
A601001150, A601001151, A601001152, A601001153, A601001154, A601001155,  
A601001156, A601001157, A601001158, A601001159, A601001160, A601001161,  
A601001162, A601001163, A601001164, A601001165, A601001170, A601001172,  
A601001177, A601001178, A601001183, A601001185, A601001199, A601001200,  
A601001202, A601001204, A601001205, A601001241, A601001243, A601001245,  
A601001246, A601001248, A601001250, A601001252, A601001253, A601001255,  
A601001256, A601001258, A601001259, A601001261, A601001263, A601001264,  
A601001266, A601001268, A601001269, A601001271, A601001272, A601001274,  
A601001326, A601001328, A601001330, A601001332, A601001333, A601001335,  
A601001337, A601001339, A601001340, A601001342, A601001344, A601001346,  
A601001347, A601001349, A601001351, A601001353, A601001354, A601001356,  
A601001358, A601001360, A601001361, A601001363, A601001365, A601001367,  
A601001369, A601001370, A601001372, A601001374, A601001376, A601001377,  
A601001379, A601001381, A601001383, A601001384, A601001386, A601001388,  
A601001390, A601001391, A601001393, A601001395, A601001397, A601001398,  
A601001400, A601001402, A601001404, A601001405, A601001406, A601001407,  
A601001408, A601001409, A601001410, A601001411, A601001412, A601001413,  
A601001414, A601001416, A601001418, A601001422, A601001424, A601001427,  
A601001429, A601001448, A601001450, A601001454, A601001456, A601001459,  
A601001461, A601001465, A601001501, A601001502, A601001504, A601001506,  
A601001508, A601001510, A601001512, A601001515, A601001517, A601001532,  
A601001534, A601001536, A601001538, A601001540, A601001543, A601001545,  
A601001558, A601001561, A601001564, A601001566, A601001569, A601001572,  
A601001574, A601001577, A601001580, A601001582, A601001585, A601001588,  
A601001590, A601001593, A601001596, A601001598, A601001601, A601001604,  
A601001606, A601001609, A601001612, A601001614, A601001617, A601001620,  
A601001622, A601001624, A601001625, A601001628, A601001629, A601001632,  
A601001634, A601001636, A601001639, A601001641, A601001644, A601001646,  
A601001653, A601001655, A601001657, A601001666, A601001669, A601001671,  
A601001673, A601001676, A601001678, A601001681, A601001683, A601001685,  
A601001687, A601001688, A601001690, A601001691, A601001697, A601001703,  
A601001705, A601001706, A601001712, A601001713, A601001715, A601001717,  
A601001723, A601001724, A601001730, A601001732, A601001737, A601001739,  
A601001753, A601001755, A601001761, A601001763, A601001768, A601001774,  
A601001776, A601001777, A601001778, A601001779, A601001780, A601001781,  
A601001782, A601001783, A601001784, A601001785, A601001786, A601001787,  
A601001788, A601001789, A601001790, A601001791, A601001792, A601001793,



A601001797, A601001799, A601001847, A601001849, A601001862, A601001864,  
A601001869, A601001870, A601001871, A601001872, A601001873, A601001874,  
A601001875, A601001876, A601001877, A601001878, A601001879, A601001888,  
A601001890, A601001903, A601001908, A601001912, A601001924, A601001929,  
A601001971, A601001975, A601001979, A601002022, A601002023, A601002024,  
A601002025, A601002026, A601002027, A601002028, A601002029, A601002030,  
A601002031, A601002032, A601002033, A601002034, A601002035, A601002036,  
A601002037, A601002038, A601002039, A601002040, A601002041, A601002042,  
A601002043, A601002164, A601002166, A601002207, A601002208, A601002213,  
A601002214, A601002219, A601002220, A601002225, A601002226, A601002231,  
A601002232, A601002237, A601002238, A601002243, A601002244, A601002249,  
A601002250, A601002255, A601002279, A601002281, A601002282, A601002288,  
A601002289, A601002294, A601002295, A601002301, A601002302, A601002308,  
A601002309, A601002315, A601002316, A601002322, A601002323, A601002328,  
A601002329, A601002335, A601002336, A601002342, A601002343, A601002349,  
A601002350, A601002358, A601002362, A601002364, A601002369, A601002371,  
A601002376, A601002380, A601002383, A601002387, A601002390, A601002394,  
A601002396, A601002401, A601002406, A601002408, A601002412, A601002415,  
A601002419, A601002422, A601002423, A601002428, A601002429, A601002435,  
A601002436, A601002438, A601002439, A601002445, A601002446, A601002448,  
A601002449, A601002455, A601002456, A601002458, A601002459, A601002465,  
A601002466, A601002472, A601002473, A601002475, A601002476, A601002482,  
A601002483, A601002485, A601002486, A601002492, A601002493, A601002498,  
A601002499, A601002504, A601002505, A601002521, A601002522, A601002527,  
A601002528, A601002535, A601002536, A601002550, A601002551, A601002558,  
A601002559, A601002580, A601002581, A601002584, A601002585, A601002588,  
A601002589, A601002590, A601002591, A601002594, A601002595, A601002596,  
A601002597, A601002601, A601002602, A601002605, A601002606, A601002607,  
A601002608, A601002611, A601002612, A601002615, A601002616, A601002617,  
A601002618, A601002621, A601002622, A601002623, A601002624, A601002627,  
A601002628, A601002631, A601002632, A601002633, A601002634, A601002637,  
A601002638, A601002642, A601002643, A601002644, A601002645, A601002648,  
A601002649, A601002651, A601002652, A601002653, A601002654, A601002655,  
A601002657, A601002658, A601002726, A601002727, A601002764, A601002765,  
A601002766, A601002767, A601002768, A601002770, A601002772, A601002773,  
A601002775, A601002776, A601003026, A601003028, A601003029, A601003031,  
A601003032, A601003034, A601003035, A601003037, A601003038, A601003040,  
A601003041, A601003042, A601003044, A601003045, A601003047, A601003048,



A601003050, A601003051, A601003053, A601003054, A601003056, A601003057,  
A601003059, A601003060, A601003061, A601003063, A601003064, A601003066,  
A601003067, A601003069, A601003268, A601003270, A601003272, A601003274,  
A601003276, A601003278, A601003281, A601003283, A601003285, A601003287,  
A601003289, A601003291, A601003307, A601003308, A601003309, A601003310,  
A601003311, A601003312, A601003313, A601003314, A601003315, A601003316,  
A601003317, A601003318, A601003319, A601003320, A601003321, A601003322,  
A601003323, A601003324, A601003325, A601003326, A601003327, A601003328,  
A601003329, A601003330, A601003331, A601003332, A601003333, A601003334,  
A601003335, A601003336, A601003337, A601003338, A601003339, A601003340,  
A601003341, A601003342, A601003343, A601003344, A601003345, A601003346,  
A601003347, A601003348, A601003349, A601003350, A601003351, A601003352,  
A601003353, A601003354, A601003355, A601003356, A601003357, A601003358,  
A601003359, A601003360, A601003361, A601003362, A601003363, A601003364,  
A601003365, A601003366, A601003367, A601003368, A601003369, A601003370,  
A601003410, A601003411, A601003412, A601003413, A601003414, A601003415,  
A601003416, A601003417, A601003418, A601003419, A601003420, A601003421,  
A601003422, A601003423, A601003424, A601003425, A601003432, A601003433,  
A601003434, A601003435, A601003436, A601003437, A601003438, A601003439,  
A601003440, A601003441, A601003442, A601003443, A601003444, A601003445,  
A601003446, A601003447, A601003448, A601003449, A601003450, A601003451,  
A601003452, A601003453, A601003454, A601003455, A601003456, A601003457,  
A601003458, A601003459, A601003460, A601003461, A601003462, A601003463,  
A601003464, A601003465, A601003466, A601003467, A601003468, A601003469,  
A601003551, A601003552, A601003553, A601003554, A601003555, A601003556,  
A601003557, A601003558, A601003559, A601003560, A601003561, A601003562,  
A601003563, A601003564, A601003565, A601003566, A601003567, A601003568,  
A601003569, A601003570, A601003571, A601003572, A601003573, A601003574,  
A601003575, A601003576, A601003709, A601003711, A601003712, A601003714,  
A601003716, A601003717, A601003719, A601003720, A601003722, A601003723,  
A601003725, A601003757, A601003758, A601003760, A601003761, A601003763,  
A601003765, A601003766, A601003768, A601003769, A601003771, A601003773,  
A601003774, A601003776, A601003777, A601003779, A601003781, A601003782,  
A601003784, A601003785, A601003787, A601003789, A601003790, A601003792,  
A601003793, A601003795, A601003797, A601003798, A601003800, A601003859,  
A601003860, A601003862, A601003863, A601003864, A601003866, A601003867,  
A601003869, A601003870, A601003872, A601003873, A601003875, A601003876,  
A601003878, A601003879, A601003881, A601003883, A601003884, A601003886,





A601003887, A601003889, A601003890, A601003892, A601003893, A601003895,  
A601003897, A601003898, A601003900, A601003901, A601003903, A601003948,  
A601003950, A601003965, A601003967, A601003968, A601003970, A601003972,  
A601003974, A601003975, A601003977, A601003979, A601003980, A601003982,  
A601003984, A601003985, A601003987, A601003989, A601003991, A601003992,  
A601003994, A601003996, A601003997, A601003999, A601004001, A601004002,  
A601004004, A601004006, A601004008, A601004009, A601004011, A601004013,  
A601004014, A601004016, A601004018, A601004020, A601004021, A601004023,  
A601004025, A601004042, A601004043, A601004045, A601004102, A601004103,  
A601004105, A601004106, A601004107, A601004108, A601004109, A601004110,  
A601004112, A601004113, A601004114, A601004115, A601004116, A601004117,  
A601004118, A601004119, A601004120, A601004121, A601004122, A601004123,  
A601004124, A601004125, A601004126, A601004127, A601004128, A601004129,  
A601004130, A601004131, A601004132, A601004133, A601004134, A601004135,  
A601004136, A601004137, A601004138, A601004139, A601004140, A601004141,  
A601004142, A601004143, A601004144, A601004145, A601004146, A601004147,  
A601004148, A601004149, A601004150, A601004442, A601004445, A601004449,  
A601004452, A601004455, A601004458, A601004462, A601004465, A601004468,  
A601004471, A601004475, A601004478, A601004481, A601004484, A601004542,  
A601004547, A601004548, A601004549, A601004550, A601004551, A601004602,  
A601004603, A601004604, A601004605, A601004606, A601004607, A601004608,  
A601004609, A601004610, A601004611, A601004612, A601004613, A601004614,  
A601004615, A601004616, A601004617, A601004618, A601004619, A601004620,  
A601004621, A601004622, A601004623, A601004624, A601004625, A601004626,  
A601004627, A601004628, A601004629, A601004630, A601004680, A601004685,  
A601004686, A601004692, A601004693, A601004698, A601004699, A601004704,  
A601004705, A601004710, A601004711, A601004716, A601004717, A601004722,  
A601004723, A601004878, A601004884, A601004885, A601004886, A601004891,  
A601004892, A601004899, A601004900, A601004907, A601004908, A601004915,  
A601004916, A601004923, A601004924, A601004931, A601004932, A601004939,  
A601004940, A601004947, A601004948, A601004954, A601004955, A601004956,  
A601004957, A601004962, A601004963, A601004968, A601004969, A601004974,  
A601004975, A601004980, A601004981, A601004986, A601004987, A601004992,  
A601004993, A601004998, A601004999, A601005004, A601005005, A601005006,  
A601005007, A601005012, A601005013, A601005014, A601005015, A601005020,  
A601005021, A601005022, A601005023, A601005028, A601005029, A601005030,  
A601005031, A601005036, A601005037, A601005038, A601005039, A601005044,  
A601005045, A601005046, A601005047, A601005052, A601005053, A601005054,



A601005055, A601005056, A601005057, A601005062, A601005063, A601005064,  
A601005065, A601005066, A601005067, A601005072, A601005073, A601005074,  
A601005075, A601005076, A601005077, A601005082, A601005083, A601005084,  
A601005085, A601005086, A601005087, A601005092, A601005093, A601005094,  
A601005095, A601005096, A601005097, A601005126, A601005127, A601005128,  
A601005129, A601005130, A601005131, A601005132, A601005133, A601005134,  
A601005135, A601005136, A601005137, A601005138, A601005139, A601005140,  
A601005141, A601005142, A601005143, A601005144, A601005145, A601005146,  
A601005147, A601005148, A601005149, A601005150, A601005151, A601005152,  
A601005153, A601005154, A601005155, A601005156, A601005157, A601005158,  
A601005159, A601005160, A601005161, A601005162, A601005163, A601005164,  
A601005165, A601005166, A601005186, A601005191, A601005192, A601005193,  
A601005194, A601005195, A601005196, A601005199, A601005200, A601005201,  
A601005202, A601005203, A601005204, A601005207, A601005208, A601005209,  
A601005210, A601005211, A601005212, A601005215, A601005216, A601005217,  
A601005218, A601005219, A601005220, A601005223, A601005224, A601005225,  
A601005226, A601005227, A601005228, A601005229, A601005230, A601005233,  
A601005234, A601005235, A601005236, A601005237, A601005238, A601005239,  
A601005240, A601005243, A601005244, A601005245, A601005246, A601005247,  
A601005248, A601005249, A601005250, A601005253, A601005254, A601005255,  
A601005256, A601005257, A601005258, A601005259, A601005260, A601005263,  
A601005264, A601005265, A601005266, A601005267, A601005268, A601005269,  
A601005270, A601005273, A601005274, A601005275, A601005276, A601005277,  
A601005278, A601005279, A601005280, A601005284, A601005285, A601005286,  
A601005287, A601005288, A601005289, A601005290, A601005291, A601005292,  
A601005293, A601005294, A601005295, A601005296, A601005297, A601005298,  
A601005299, A601005300, A601005301, A601005302, A601005303, A601005304,  
A601005305, A601005306, A601005307, A601005308, A601005309, A601005310,  
A601005311, A601005312, A601005313, A601005314, A601005315, A601005316,  
A601005317, A601005318, A601005319, A601005320, A601005321, A601005322,  
A601005323, A601005324, A601005325, A601005326, A601005327, A601005329,  
A601005330, A601005331, A601005332, A601005333, A601005364, A601005365,  
A601005366, A601005367, A601005368, A601005369, A601005370, A601005371,  
A601005372, A601005373, A601005374, A601005375, A601005376, A601005377,  
A601005378, A601005379, A601005380, A601005381, A601005382, A601005383,  
A601005384, A601005385, A601005386, A601005387, A601005388, A601005393

**CE: SJ20E**



A601004857, A601004858, A601004859, A601004860, A601004865, A601004866,  
A601004867, A601004868, A601004873, A601004874, A601004875, A601004876,  
A601004879, A601004880, A601004881, A601004882, A601004883, A601005008,  
A601005009, A601005010, A601005011, A601005016, A601005017, A601005018,  
A601005019, A601005328, A601005492, A601005493, A601005494, A601005495,  
A601005496, A601005497, A601005498, A601005499, A601005500, A601005501,  
A601005502, A601005503, A601005504, A601005505, A601005506, A601005507,  
A601005508, A601005509, A601005510, A601005511, A601005512, A601005513,  
A601005514, A601005515, A601005516, A601005517, A601005518, A601005519,  
A601005520, A601005521, A601005522, A601005523, A601005524, A601005525,  
A601005526, A601005527, A601005528, A601005529, A601005530, A601005531,  
A601005532, A601005533, A601005534, A601005535, A601005536, A601005537,  
A601005538, A601005539, A601005540, A601005541, A601005542, A601005544,  
A601005545, A601005547, A601005548, A601005549, A601005550, A601005551,  
A601005552, A601005553, A601005554, A601005555, A601005556, A601005557,  
A601005558, A601005559, A601005560, A601005561, A601005562, A601005563,  
A601005564, A601005565, A601005566, A601005567, A601005568, A601005569,  
A601005570, A601005571, A601005572, A601005573, A601005574, A601005575,  
A601005578, A601005579, A601005580, A601005581, A601005582, A601005583,  
A601005584, A601005585, A601005586, A601005587, A601005588

**NA: SJ12E**

A601000910, A601000911, A601000914, A601001490, A601001491, A601001492,  
A601001493, A601001494, A601001495, A601001496, A601001497, A601001498,  
A601001499, A601001523, A601002053, A601002055, A601002058, A601002061,  
A601002130, A601002132, A601002134, A601002147, A601002161, A601002163,  
A601002180, A601002182, A601002195, A601002197, A601002826, A601002829,  
A601002832, A601002835, A601002838, A601002840, A601002843, A601003012,  
A601003013, A601003015, A601003016, A601003145, A601003146, A601003147,  
A601003149, A601003150, A601003151, A601003152, A601003153, A601003154,  
A601003158, A601003159, A601003160, A601003161, A601003162, A601003293,  
A601003801, A601003803, A601003804, A601003806, A601003807, A601003809,  
A601003951, A601003953, A601003955, A601004046, A601004047, A601004048,  
A601004049, A601004050, A601004051, A601004053, A601004054, A601004055,  
A601004101, A601004151, A601004152, A601004153, A601004154, A601004155,  
A601004156, A601004157, A601004158, A601004159, A601004160, A601004161,  
A601004162, A601004163, A601004164, A601004165, A601004166, A601004167,  
A601004174, A601004312, A601004313, A601004315, A601004316, A601004317,



A601004318, A601004320, A601004321, A601004322, A601004355, A601004358,  
A601004367, A601004370, A601004544, A601004545, A601004546, A601004584,  
A601004585, A601004586, A601004587, A601004588, A601004589, A601004590,  
A601004770, A601004771, A601004772, A601004773, A601004774, A601004775,  
A601004776, A601004781, A601004837, A601004838, A601004839, A601004840,  
A601005171, A601005172, A601005173, A601005174, A601005175, A601005176,  
A601005181, A601005182, A601005183, A601005184, A601005185

**NA: SJ16E**

A601000909, A601000912, A601000918, A601000919, A601000922, A601000925,  
A601000937, A601000943, A601000946, A601000952, A601000955, A601000958,  
A601000964, A601000966, A601000970, A601000972, A601000976, A601000978,  
A601000980, A601000982, A601000986, A601000988, A601000992, A601000994,  
A601000996, A601000997, A601001124, A601001207, A601001209, A601001210,  
A601001212, A601001214, A601001215, A601001217, A601001218, A601001220,  
A601001222, A601001223, A601001225, A601001227, A601001288, A601001290,  
A601001292, A601001293, A601001295, A601001296, A601001298, A601001300,  
A601001301, A601001303, A601001304, A601001306, A601001308, A601001420,  
A601001431, A601001452, A601001463, A601001519, A601001521, A601001524,  
A601001525, A601001526, A601001527, A601001528, A601001529, A601001547,  
A601001549, A601001551, A601001553, A601001556, A601001648, A601001651,  
A601001659, A601001660, A601001661, A601001662, A601001663, A601001664,  
A601001693, A601001695, A601001699, A601001701, A601001708, A601001710,  
A601001719, A601001721, A601001726, A601001728, A601001734, A601001735,  
A601001744, A601001745, A601001746, A601001747, A601001748, A601001750,  
A601001752, A601001757, A601001759, A601001764, A601001766, A601001794,  
A601001795, A601001801, A601001802, A601001804, A601001806, A601001808,  
A601001810, A601001812, A601001814, A601001816, A601001818, A601001820,  
A601001822, A601001824, A601001843, A601001845, A601001854, A601001856,  
A601001880, A601001882, A601001895, A601001897, A601001905, A601001916,  
A601001920, A601001962, A601001967, A601001983, A601002014, A601002045,  
A601002048, A601002063, A601002066, A601002068, A601002071, A601002073,  
A601002076, A601002079, A601002081, A601002084, A601002086, A601002089,  
A601002091, A601002094, A601002097, A601002136, A601002138, A601002140,  
A601002142, A601002144, A601002145, A601002149, A601002151, A601002153,  
A601002155, A601002157, A601002159, A601002168, A601002170, A601002172,  
A601002174, A601002176, A601002178, A601002183, A601002185, A601002187,  
A601002189, A601002191, A601002193, A601002199, A601002201, A601002203,



A601002204, A601002205, A601002210, A601002211, A601002216, A601002217,  
A601002222, A601002223, A601002228, A601002229, A601002234, A601002235,  
A601002240, A601002241, A601002246, A601002247, A601002252, A601002253,  
A601002256, A601002257, A601002284, A601002285, A601002291, A601002292,  
A601002298, A601002299, A601002305, A601002306, A601002311, A601002312,  
A601002318, A601002319, A601002325, A601002326, A601002332, A601002333,  
A601002339, A601002340, A601002345, A601002346, A601002352, A601002353,  
A601002356, A601002360, A601002367, A601002374, A601002378, A601002385,  
A601002392, A601002399, A601002403, A601002410, A601002417, A601002425,  
A601002426, A601002432, A601002433, A601002442, A601002443, A601002452,  
A601002453, A601002462, A601002463, A601002468, A601002469, A601002478,  
A601002479, A601002488, A601002489, A601002495, A601002496, A601002501,  
A601002502, A601002507, A601002508, A601002510, A601002511, A601002516,  
A601002517, A601002518, A601002519, A601002524, A601002525, A601002530,  
A601002531, A601002532, A601002533, A601002538, A601002539, A601002541,  
A601002542, A601002547, A601002552, A601002553, A601002555, A601002556,  
A601002561, A601002562, A601002563, A601002564, A601002566, A601002575,  
A601002576, A601002577, A601002582, A601002583, A601002586, A601002587,  
A601002592, A601002593, A601002598, A601002599, A601002603, A601002604,  
A601002609, A601002610, A601002613, A601002614, A601002619, A601002620,  
A601002625, A601002626, A601002629, A601002630, A601002635, A601002636,  
A601002640, A601002641, A601002646, A601002647, A601002650, A601002663,  
A601002664, A601002665, A601002666, A601002668, A601002669, A601002670,  
A601002671, A601002672, A601002678, A601002679, A601002680, A601002682,  
A601002684, A601002685, A601002686, A601002687, A601002689, A601002690,  
A601002691, A601002692, A601002693, A601002695, A601002696, A601002697,  
A601002698, A601002699, A601002701, A601002702, A601002703, A601002704,  
A601002705, A601002707, A601002708, A601002709, A601002710, A601002712,  
A601002713, A601002714, A601002715, A601002716, A601002718, A601002719,  
A601002720, A601002721, A601002722, A601002724, A601002725, A601002729,  
A601002731, A601002732, A601002734, A601002735, A601002737, A601002739,  
A601002740, A601002742, A601002743, A601002745, A601002747, A601002748,  
A601002750, A601002751, A601002753, A601002755, A601002756, A601002758,  
A601002760, A601002761, A601002763, A601002796, A601002798, A601002801,  
A601002804, A601002807, A601002810, A601002812, A601002815, A601002818,  
A601002821, A601002824, A601002864, A601002867, A601002870, A601002873,  
A601002875, A601002878, A601002881, A601002883, A601002886, A601002889,  
A601002891, A601002894, A601002897, A601002899, A601002902, A601002905,



A601002907, A601002910, A601002913, A601002915, A601002918, A601002921,  
A601002923, A601002926, A601002929, A601002931, A601002938, A601002940,  
A601002942, A601002943, A601002945, A601002946, A601002948, A601002950,  
A601002951, A601002953, A601002954, A601002956, A601002958, A601002959,  
A601002961, A601002962, A601002964, A601002966, A601002967, A601002969,  
A601002970, A601002972, A601002974, A601002975, A601002977, A601002978,  
A601002980, A601002982, A601002983, A601002985, A601002986, A601002988,  
A601002990, A601002991, A601002993, A601002994, A601002996, A601002998,  
A601002999, A601003001, A601003002, A601003004, A601003006, A601003007,  
A601003009, A601003010, A601003070, A601003072, A601003073, A601003075,  
A601003077, A601003078, A601003080, A601003081, A601003083, A601003084,  
A601003086, A601003087, A601003089, A601003091, A601003092, A601003094,  
A601003095, A601003097, A601003098, A601003100, A601003102, A601003103,  
A601003105, A601003106, A601003108, A601003109, A601003111, A601003112,  
A601003114, A601003116, A601003117, A601003119, A601003120, A601003122,  
A601003123, A601003125, A601003127, A601003128, A601003130, A601003131,  
A601003133, A601003134, A601003136, A601003137, A601003139, A601003141,  
A601003142, A601003144, A601003163, A601003164, A601003166, A601003167,  
A601003168, A601003169, A601003170, A601003171, A601003173, A601003174,  
A601003175, A601003176, A601003177, A601003178, A601003180, A601003181,  
A601003182, A601003183, A601003184, A601003185, A601003186, A601003188,  
A601003189, A601003190, A601003191, A601003192, A601003193, A601003195,  
A601003196, A601003197, A601003198, A601003199, A601003200, A601003202,  
A601003203, A601003204, A601003205, A601003206, A601003207, A601003208,  
A601003210, A601003211, A601003212, A601003213, A601003214, A601003215,  
A601003217, A601003218, A601003219, A601003221, A601003223, A601003225,  
A601003227, A601003229, A601003231, A601003233, A601003236, A601003238,  
A601003240, A601003242, A601003244, A601003246, A601003248, A601003426,  
A601003428, A601003429, A601003431, A601003501, A601003503, A601003504,  
A601003505, A601003507, A601003508, A601003810, A601003812, A601003813,  
A601003814, A601003816, A601003817, A601003819, A601003820, A601003822,  
A601003823, A601003825, A601003826, A601003828, A601003829, A601003831,  
A601003832, A601003834, A601003835, A601003837, A601003838, A601003839,  
A601003841, A601003842, A601003844, A601003845, A601003847, A601003848,  
A601003850, A601003851, A601003853, A601003854, A601003856, A601003857,  
A601003929, A601003931, A601003933, A601003934, A601003936, A601003937,  
A601003939, A601003940, A601003942, A601003943, A601003945, A601003947,  
A601004056, A601004057, A601004058, A601004060, A601004061, A601004062,



A601004063, A601004064, A601004065, A601004066, A601004068, A601004069,  
A601004070, A601004071, A601004072, A601004073, A601004075, A601004076,  
A601004077, A601004078, A601004079, A601004080, A601004081, A601004083,  
A601004084, A601004085, A601004086, A601004087, A601004088, A601004090,  
A601004091, A601004092, A601004093, A601004094, A601004095, A601004096,  
A601004098, A601004099, A601004100, A601004168, A601004169, A601004171,  
A601004172, A601004173, A601004175, A601004181, A601004183, A601004185,  
A601004188, A601004190, A601004192, A601004196, A601004199, A601004205,  
A601004207, A601004210, A601004212, A601004216, A601004219, A601004221,  
A601004232, A601004234, A601004236, A601004238, A601004241, A601004251,  
A601004252, A601004254, A601004255, A601004256, A601004282, A601004283,  
A601004284, A601004286, A601004287, A601004288, A601004289, A601004291,  
A601004292, A601004294, A601004295, A601004296, A601004297, A601004299,  
A601004488, A601004491, A601004494, A601004497, A601004501, A601004504,  
A601004507, A601004511, A601004515, A601004519, A601004523, A601004527,  
A601004531, A601004535, A601004539, A601004552, A601004553, A601004554,  
A601004555, A601004556, A601004557, A601004558, A601004559, A601004560,  
A601004561, A601004562, A601004563, A601004564, A601004565, A601004566,  
A601004567, A601004568, A601004569, A601004570, A601004571, A601004572,  
A601004573, A601004574, A601004575, A601004576, A601004577, A601004578,  
A601004579, A601004580, A601004581, A601004582, A601004583, A601004591,  
A601004592, A601004593, A601004594, A601004595, A601004596, A601004597,  
A601004598, A601004599, A601004600, A601004601, A601004635, A601004636,  
A601004641, A601004642, A601004647, A601004648, A601004653, A601004654,  
A601004659, A601004660, A601004665, A601004666, A601004671, A601004672,  
A601004679, A601004727, A601004728, A601004733, A601004734, A601004739,  
A601004740, A601004745, A601004746, A601004752, A601004753, A601004758,  
A601004764, A601004765, A601004782, A601004787, A601004788, A601004793,  
A601004794, A601004798, A601004799, A601004804, A601004805, A601004810,  
A601004811, A601004816, A601004817, A601004845, A601004846, A601004847,  
A601004848, A601004853, A601004854, A601004855, A601004856, A601004861,  
A601004862, A601004863, A601004864, A601004869, A601004870, A601004871,  
A601004872, A601004877, A601005477, A601005478

**NA: SJ20E**

A601000763, A601000764, A601000765, A601000766, A601000767, A601000768,  
A601000769, A601000770, A601000771, A601000772, A601000773, A601000774,  
A601000775, A601000776, A601000777, A601000778, A601000779, A601000780,





A601000781, A601000792, A601000793, A601000794, A601000795, A601000796,  
A601000797, A601000798, A601000799, A601000800, A601000801, A601000802,  
A601000803, A601000804, A601000805, A601000806, A601000807, A601000808,  
A601000809, A601000810, A601000811, A601000812, A601000813, A601000814,  
A601000815, A601000816, A601000817, A601000818, A601000819, A601000820,  
A601000821, A601000822, A601000823, A601000824, A601000825, A601000826,  
A601000827, A601000828, A601000829, A601000830, A601000831, A601000832,  
A601000833, A601000834, A601000835, A601000836, A601000837, A601000838,  
A601000839, A601000840, A601000841, A601000842, A601000843, A601000844,  
A601000845, A601000846, A601000847, A601000848, A601000849, A601000850,  
A601000851, A601000852, A601000853, A601000854, A601000855, A601000856,  
A601000857, A601000858, A601000859, A601000860, A601000861, A601000862,  
A601000863, A601000864, A601000865, A601000866, A601000867, A601000868,  
A601000869, A601000870, A601000871, A601000872, A601000873, A601000874,  
A601000875, A601000876, A601000877, A601000878, A601000879, A601000880,  
A601000881, A601000882, A601000883, A601000884, A601000885, A601000886,  
A601000887, A601000888, A601000889, A601000890, A601000891, A601000892,  
A601000893, A601000894, A601000895, A601000896, A601000897, A601000898,  
A601000899, A601000900, A601000901, A601000902, A601000903, A601000904,  
A601000905, A601000916, A601000917, A601000920, A601000921, A601000923,  
A601000924, A601000926, A601000927, A601000929, A601000930, A601000932,  
A601000933, A601000935, A601000936, A601000938, A601000939, A601000941,  
A601000942, A601000944, A601000945, A601000947, A601000948, A601000950,  
A601000951, A601000953, A601000954, A601000956, A601000957, A601000959,  
A601000960, A601000962, A601000963, A601000965, A601000967, A601000969,  
A601000971, A601000973, A601000975, A601000977, A601000979, A601000981,  
A601000983, A601000985, A601000987, A601000989, A601000991, A601000993,  
A601000995, A601000998, A601001000, A601001017, A601001019, A601001021,  
A601001023, A601001025, A601001027, A601001029, A601001031, A601001033,  
A601001035, A601001037, A601001039, A601001040, A601001041, A601001077,  
A601001080, A601001083, A601001086, A601001089, A601001092, A601001095,  
A601001098, A601001101, A601001102, A601001105, A601001108, A601001111,  
A601001114, A601001117, A601001120, A601001123, A601001125, A601001128,  
A601001131, A601001134, A601001135, A601001138, A601001166, A601001169,  
A601001171, A601001173, A601001176, A601001179, A601001182, A601001184,  
A601001186, A601001193, A601001195, A601001198, A601001201, A601001203,  
A601001206, A601001208, A601001211, A601001213, A601001216, A601001219,  
A601001221, A601001224, A601001226, A601001229, A601001231, A601001234,





A601001237, A601001239, A601001242, A601001244, A601001247, A601001249,  
A601001251, A601001254, A601001257, A601001260, A601001262, A601001265,  
A601001267, A601001270, A601001273, A601001275, A601001278, A601001281,  
A601001284, A601001287, A601001289, A601001291, A601001294, A601001297,  
A601001299, A601001302, A601001305, A601001307, A601001309, A601001312,  
A601001315, A601001318, A601001320, A601001323, A601001327, A601001329,  
A601001331, A601001334, A601001336, A601001338, A601001341, A601001343,  
A601001345, A601001348, A601001350, A601001352, A601001355, A601001357,  
A601001359, A601001362, A601001364, A601001366, A601001368, A601001371,  
A601001373, A601001375, A601001378, A601001380, A601001382, A601001385,  
A601001387, A601001389, A601001392, A601001394, A601001396, A601001399,  
A601001401, A601001403, A601001415, A601001417, A601001419, A601001421,  
A601001423, A601001425, A601001426, A601001428, A601001430, A601001432,  
A601001434, A601001436, A601001447, A601001449, A601001451, A601001453,  
A601001455, A601001457, A601001458, A601001460, A601001462, A601001464,  
A601001466, A601001467, A601001500, A601001503, A601001505, A601001507,  
A601001509, A601001511, A601001513, A601001514, A601001516, A601001518,  
A601001520, A601001522, A601001530, A601001531, A601001533, A601001535,  
A601001537, A601001539, A601001541, A601001542, A601001544, A601001546,  
A601001548, A601001550, A601001552, A601001554, A601001555, A601001557,  
A601001559, A601001560, A601001562, A601001563, A601001565, A601001567,  
A601001568, A601001570, A601001571, A601001573, A601001575, A601001576,  
A601001578, A601001579, A601001581, A601001583, A601001584, A601001586,  
A601001587, A601001589, A601001591, A601001592, A601001594, A601001595,  
A601001597, A601001599, A601001600, A601001602, A601001603, A601001605,  
A601001607, A601001608, A601001610, A601001611, A601001613, A601001615,  
A601001616, A601001618, A601001619, A601001621, A601001623, A601001626,  
A601001627, A601001630, A601001631, A601001633, A601001635, A601001637,  
A601001638, A601001640, A601001642, A601001643, A601001645, A601001647,  
A601001649, A601001650, A601001652, A601001654, A601001656, A601001658,  
A601001665, A601001667, A601001668, A601001670, A601001672, A601001674,  
A601001675, A601001677, A601001679, A601001680, A601001682, A601001684,  
A601001686, A601001689, A601001692, A601001694, A601001696, A601001698,  
A601001700, A601001702, A601001704, A601001707, A601001709, A601001711,  
A601001714, A601001716, A601001718, A601001720, A601001722, A601001725,  
A601001727, A601001729, A601001731, A601001733, A601001736, A601001738,  
A601001740, A601001741, A601001742, A601001743, A601001749, A601001751,  
A601001754, A601001756, A601001758, A601001760, A601001762, A601001765,



A601001767, A601001769, A601001773, A601001775, A601001796, A601001798,  
A601001803, A601001805, A601001807, A601001809, A601001811, A601001813,  
A601001815, A601001817, A601001819, A601001821, A601001823, A601001825,  
A601001826, A601001827, A601001828, A601001829, A601001830, A601001831,  
A601001832, A601001833, A601001834, A601001835, A601001836, A601001837,  
A601001838, A601001840, A601001842, A601001844, A601001846, A601001848,  
A601001850, A601001853, A601001855, A601001857, A601001859, A601001861,  
A601001863, A601001865, A601001868, A601001881, A601001883, A601001885,  
A601001887, A601001889, A601001891, A601001894, A601001896, A601001898,  
A601001900, A601001902, A601001904, A601001906, A601001907, A601001909,  
A601001910, A601001911, A601001913, A601001914, A601001915, A601001917,  
A601001918, A601001919, A601001921, A601001922, A601001923, A601001925,  
A601001926, A601001927, A601001928, A601001930, A601001931, A601001932,  
A601001934, A601001935, A601001936, A601001938, A601001939, A601001940,  
A601001941, A601001942, A601001943, A601001944, A601001945, A601001946,  
A601001947, A601001948, A601001949, A601001950, A601001951, A601001952,  
A601001953, A601001954, A601001955, A601001956, A601001957, A601001958,  
A601001959, A601001960, A601001961, A601001963, A601001964, A601001965,  
A601001966, A601001968, A601001969, A601001970, A601001972, A601001973,  
A601001974, A601001976, A601001977, A601001978, A601001980, A601001981,  
A601001982, A601001984, A601001985, A601001986, A601001988, A601001989,  
A601001990, A601001991, A601001992, A601001993, A601001994, A601001995,  
A601001996, A601001997, A601001998, A601001999, A601002000, A601002001,  
A601002002, A601002003, A601002004, A601002005, A601002006, A601002007,  
A601002009, A601002010, A601002012, A601002013, A601002015, A601002016,  
A601002018, A601002019, A601002021, A601002044, A601002046, A601002047,  
A601002049, A601002050, A601002052, A601002054, A601002056, A601002057,  
A601002059, A601002060, A601002062, A601002064, A601002065, A601002067,  
A601002069, A601002070, A601002072, A601002074, A601002075, A601002077,  
A601002078, A601002080, A601002082, A601002083, A601002085, A601002087,  
A601002088, A601002090, A601002092, A601002093, A601002095, A601002096,  
A601002098, A601002100, A601002101, A601002103, A601002105, A601002106,  
A601002108, A601002109, A601002111, A601002113, A601002114, A601002116,  
A601002118, A601002119, A601002121, A601002123, A601002124, A601002127,  
A601002129, A601002131, A601002133, A601002135, A601002137, A601002139,  
A601002141, A601002143, A601002146, A601002148, A601002150, A601002152,  
A601002154, A601002156, A601002158, A601002160, A601002162, A601002165,  
A601002167, A601002169, A601002171, A601002173, A601002175, A601002177,



A601002179, A601002181, A601002184, A601002186, A601002188, A601002190,  
A601002192, A601002194, A601002196, A601002198, A601002200, A601002202,  
A601002206, A601002209, A601002212, A601002215, A601002218, A601002221,  
A601002224, A601002227, A601002230, A601002233, A601002236, A601002239,  
A601002242, A601002245, A601002248, A601002251, A601002254, A601002258,  
A601002259, A601002260, A601002261, A601002262, A601002263, A601002264,  
A601002265, A601002266, A601002267, A601002268, A601002269, A601002270,  
A601002271, A601002272, A601002273, A601002274, A601002275, A601002276,  
A601002277, A601002278, A601002280, A601002283, A601002286, A601002287,  
A601002290, A601002293, A601002296, A601002297, A601002300, A601002303,  
A601002304, A601002307, A601002310, A601002313, A601002314, A601002317,  
A601002320, A601002321, A601002324, A601002327, A601002330, A601002331,  
A601002334, A601002337, A601002338, A601002341, A601002344, A601002347,  
A601002348, A601002351, A601002354, A601002355, A601002357, A601002359,  
A601002361, A601002363, A601002365, A601002366, A601002368, A601002370,  
A601002372, A601002373, A601002375, A601002377, A601002379, A601002381,  
A601002382, A601002384, A601002386, A601002388, A601002389, A601002391,  
A601002393, A601002395, A601002397, A601002398, A601002400, A601002402,  
A601002404, A601002405, A601002407, A601002409, A601002411, A601002413,  
A601002414, A601002416, A601002418, A601002420, A601002421, A601002424,  
A601002427, A601002430, A601002431, A601002434, A601002437, A601002440,  
A601002441, A601002444, A601002447, A601002450, A601002451, A601002454,  
A601002457, A601002460, A601002461, A601002464, A601002467, A601002470,  
A601002471, A601002474, A601002477, A601002480, A601002481, A601002484,  
A601002487, A601002490, A601002491, A601002494, A601002497, A601002500,  
A601002503, A601002506, A601002509, A601002512, A601002515, A601002520,  
A601002523, A601002526, A601002529, A601002534, A601002537, A601002540,  
A601002543, A601002546, A601002548, A601002549, A601002554, A601002557,  
A601002560, A601002565, A601002567, A601002568, A601002569, A601002570,  
A601002571, A601002572, A601002573, A601002574, A601002579, A601002600,  
A601002656, A601002662, A601002667, A601002673, A601002674, A601002675,  
A601002676, A601002677, A601002681, A601002683, A601002688, A601002694,  
A601002700, A601002706, A601002711, A601002717, A601002723, A601002728,  
A601002730, A601002733, A601002736, A601002738, A601002741, A601002744,  
A601002746, A601002749, A601002752, A601002754, A601002757, A601002759,  
A601002762, A601002769, A601002771, A601002774, A601002777, A601002779,  
A601002780, A601002781, A601002782, A601002783, A601002784, A601002785,  
A601002786, A601002787, A601002789, A601002791, A601002792, A601002794,



A601002795, A601002797, A601002799, A601002800, A601002802, A601002803,  
A601002805, A601002806, A601002808, A601002809, A601002811, A601002813,  
A601002814, A601002816, A601002817, A601002819, A601002820, A601002822,  
A601002823, A601002825, A601002827, A601002828, A601002830, A601002831,  
A601002833, A601002834, A601002836, A601002837, A601002839, A601002841,  
A601002842, A601002844, A601002845, A601002846, A601002847, A601002849,  
A601002850, A601002852, A601002853, A601002855, A601002857, A601002858,  
A601002860, A601002861, A601002863, A601002865, A601002866, A601002868,  
A601002869, A601002871, A601002872, A601002874, A601002876, A601002877,  
A601002879, A601002880, A601002882, A601002884, A601002885, A601002887,  
A601002888, A601002890, A601002892, A601002893, A601002895, A601002896,  
A601002898, A601002900, A601002901, A601002903, A601002904, A601002906,  
A601002908, A601002909, A601002911, A601002912, A601002914, A601002916,  
A601002917, A601002919, A601002920, A601002922, A601002924, A601002925,  
A601002927, A601002928, A601002930, A601002932, A601002933, A601002936,  
A601002939, A601002941, A601002944, A601002947, A601002949, A601002952,  
A601002955, A601002957, A601002960, A601002963, A601002965, A601002968,  
A601002971, A601002973, A601002976, A601002979, A601002981, A601002984,  
A601002987, A601002989, A601002992, A601002995, A601002997, A601003000,  
A601003003, A601003005, A601003008, A601003011, A601003014, A601003017,  
A601003021, A601003024, A601003027, A601003030, A601003033, A601003036,  
A601003039, A601003043, A601003046, A601003049, A601003052, A601003055,  
A601003058, A601003062, A601003065, A601003068, A601003071, A601003074,  
A601003076, A601003079, A601003082, A601003085, A601003088, A601003090,  
A601003093, A601003096, A601003099, A601003101, A601003104, A601003107,  
A601003110, A601003113, A601003115, A601003118, A601003121, A601003124,  
A601003126, A601003129, A601003132, A601003135, A601003138, A601003140,  
A601003143, A601003148, A601003155, A601003156, A601003157, A601003165,  
A601003172, A601003179, A601003187, A601003194, A601003201, A601003209,  
A601003216, A601003220, A601003224, A601003226, A601003228, A601003230,  
A601003232, A601003234, A601003235, A601003237, A601003239, A601003241,  
A601003243, A601003245, A601003247, A601003249, A601003250, A601003252,  
A601003254, A601003256, A601003258, A601003260, A601003262, A601003264,  
A601003265, A601003267, A601003269, A601003271, A601003273, A601003275,  
A601003277, A601003279, A601003280, A601003282, A601003284, A601003286,  
A601003288, A601003290, A601003292, A601003294, A601003427, A601003430,  
A601003502, A601003506, A601003509, A601003513, A601003517, A601003520,  
A601003524, A601003527, A601003531, A601003534, A601003538, A601003542,



A601003545, A601003549, A601003579, A601003587, A601003594, A601003602,  
A601003609, A601003617, A601003624, A601003632, A601003639, A601003647,  
A601003652, A601003655, A601003658, A601003661, A601003663, A601003666,  
A601003669, A601003672, A601003675, A601003678, A601003681, A601003684,  
A601003687, A601003689, A601003692, A601003695, A601003698, A601003701,  
A601003704, A601003707, A601003710, A601003713, A601003715, A601003718,  
A601003721, A601003724, A601003727, A601003730, A601003732, A601003735,  
A601003738, A601003740, A601003743, A601003746, A601003748, A601003751,  
A601003754, A601003756, A601003759, A601003762, A601003764, A601003767,  
A601003770, A601003772, A601003775, A601003778, A601003780, A601003783,  
A601003786, A601003788, A601003791, A601003794, A601003796, A601003799,  
A601003802, A601003805, A601003808, A601003811, A601003815, A601003818,  
A601003821, A601003824, A601003827, A601003830, A601003833, A601003836,  
A601003840, A601003843, A601003846, A601003849, A601003852, A601003855,  
A601003858, A601003861, A601003865, A601003868, A601003871, A601003874,  
A601003877, A601003880, A601003882, A601003885, A601003888, A601003891,  
A601003894, A601003896, A601003899, A601003902, A601003905, A601003907,  
A601003910, A601003913, A601003916, A601003919, A601003921, A601003924,  
A601003927, A601003930, A601003932, A601003935, A601003938, A601003941,  
A601003944, A601003946, A601003949, A601003952, A601003954, A601003957,  
A601003959, A601003961, A601003964, A601003966, A601003969, A601003971,  
A601003973, A601003976, A601003978, A601003981, A601003983, A601003986,  
A601003988, A601003990, A601003993, A601003995, A601003998, A601004000,  
A601004003, A601004005, A601004007, A601004010, A601004012, A601004015,  
A601004017, A601004019, A601004022, A601004024, A601004029, A601004037,  
A601004044, A601004052, A601004059, A601004067, A601004074, A601004082,  
A601004089, A601004097, A601004104, A601004111, A601004176, A601004197,  
A601004209, A601004211, A601004213, A601004215, A601004217, A601004218,  
A601004220, A601004222, A601004224, A601004226, A601004228, A601004229,  
A601004231, A601004233, A601004235, A601004237, A601004239, A601004240,  
A601004242, A601004244, A601004246, A601004248, A601004250, A601004253,  
A601004258, A601004264, A601004269, A601004274, A601004280, A601004285,  
A601004290, A601004293, A601004298, A601004303, A601004309, A601004314,  
A601004319, A601004325, A601004330, A601004333, A601004335, A601004336,  
A601004338, A601004339, A601004341, A601004342, A601004344, A601004345,  
A601004347, A601004348, A601004350, A601004351, A601004353, A601004354,  
A601004356, A601004357, A601004359, A601004360, A601004362, A601004363,  
A601004365, A601004366, A601004368, A601004369, A601004371, A601004372,



A601004374, A601004375, A601004376, A601004378, A601004379, A601004381,  
A601004382, A601004384, A601004385, A601004387, A601004388, A601004390,  
A601004391, A601004393, A601004394, A601004396, A601004397, A601004399,  
A601004400, A601004402, A601004403, A601004405, A601004406, A601004408,  
A601004409, A601004411, A601004412, A601004414, A601004415, A601004417,  
A601004418, A601004419, A601004420, A601004422, A601004423, A601004425,  
A601004426, A601004427, A601004429, A601004430, A601004432, A601004433,  
A601004434, A601004436, A601004437, A601004439, A601004440, A601004441,  
A601004443, A601004444, A601004448, A601004450, A601004451, A601004453,  
A601004454, A601004456, A601004457, A601004459, A601004460, A601004461,  
A601004463, A601004464, A601004466, A601004467, A601004469, A601004470,  
A601004472, A601004473, A601004474, A601004476, A601004477, A601004479,  
A601004480, A601004482, A601004483, A601004485, A601004486, A601004487,  
A601004489, A601004490, A601004492, A601004493, A601004495, A601004496,  
A601004498, A601004499, A601004500, A601004502, A601004503, A601004505,  
A601004506, A601004508, A601004509, A601004510, A601004512, A601004513,  
A601004514, A601004516, A601004517, A601004518, A601004520, A601004521,  
A601004522, A601004524, A601004525, A601004526, A601004528, A601004529,  
A601004530, A601004532, A601004533, A601004534, A601004536, A601004537,  
A601004538, A601004540, A601004541, A601004543, A601004631, A601004632,  
A601004633, A601004634, A601004637, A601004638, A601004639, A601004640,  
A601004643, A601004644, A601004645, A601004646, A601004649, A601004650,  
A601004651, A601004652, A601004655, A601004656, A601004657, A601004658,  
A601004661, A601004662, A601004663, A601004664, A601004667, A601004668,  
A601004669, A601004670, A601004675, A601004676, A601004677, A601004678,  
A601004681, A601004682, A601004683, A601004684, A601004687, A601004688,  
A601004689, A601004690, A601004694, A601004695, A601004697, A601004702,  
A601004703, A601004706, A601004707, A601004708, A601004709, A601004712,  
A601004713, A601004714, A601004715, A601004718, A601004719, A601004720,  
A601004721, A601004724, A601004725, A601004726, A601004729, A601004730,  
A601004731, A601004732, A601004744, A601004748, A601004749, A601004750,  
A601004751, A601004754, A601004755, A601004756, A601004757, A601004759,  
A601004760, A601004761, A601004762, A601004763, A601004766, A601004767,  
A601004769, A601004777, A601004778, A601004779, A601004780, A601004783,  
A601004784, A601004785, A601004786, A601004789, A601004790, A601004791,  
A601004792, A601004795, A601004796, A601004797, A601004800, A601004801,  
A601004802, A601004803, A601004806, A601004807, A601004808, A601004809,  
A601004812, A601004813, A601004814, A601004815, A601004818, A601004819,



A601004820, A601004821, A601004822, A601004823, A601004824, A601004825,  
A601004833, A601004834, A601004835, A601004836, A601004841, A601004842,  
A601004843, A601004844, A601004849, A601004850, A601004851, A601004852,  
A601004887, A601004888, A601004889, A601004890, A601004893, A601004894,  
A601004895, A601004896, A601004897, A601004898, A601004901, A601004902,  
A601004903, A601004904, A601004905, A601004906, A601004909, A601004910,  
A601004911, A601004912, A601004913, A601004914, A601004917, A601004918,  
A601004919, A601004920, A601004921, A601004922, A601004925, A601004928,  
A601004929, A601004930, A601004958, A601004959, A601004960, A601004961,  
A601004964, A601004965, A601004966, A601004967, A601004970, A601004971,  
A601004972, A601004973, A601004976, A601004977, A601004978, A601004979,  
A601004982, A601004983, A601004984, A601004989, A601004990, A601004991,  
A601004994, A601004995, A601004996, A601004997, A601005000, A601005001,  
A601005002, A601005003, A601005024, A601005025, A601005026, A601005027,  
A601005032, A601005033, A601005034, A601005035, A601005040, A601005041,  
A601005042, A601005043, A601005048, A601005049, A601005050, A601005051,  
A601005058, A601005059, A601005060, A601005061, A601005068, A601005069,  
A601005070, A601005071, A601005078, A601005079, A601005080, A601005081,  
A601005088, A601005089, A601005090, A601005091, A601005100, A601005101,  
A601005102, A601005103, A601005104, A601005105, A601005106, A601005107,  
A601005108, A601005109, A601005110, A601005111, A601005114, A601005115,  
A601005116, A601005117, A601005118, A601005119, A601005120, A601005121,  
A601005122, A601005123, A601005124, A601005125, A601005167, A601005168,  
A601005169, A601005170, A601005177, A601005178, A601005179, A601005180,  
A601005187, A601005188, A601005189, A601005190, A601005197, A601005206,  
A601005213, A601005221, A601005222, A601005231, A601005232, A601005241,  
A601005242, A601005251, A601005252, A601005261, A601005262, A601005271,  
A601005272, A601005281, A601005282, A601005283, A601005334, A601005335,  
A601005336, A601005337, A601005338, A601005339, A601005340, A601005341,  
A601005342, A601005343, A601005344, A601005345, A601005346, A601005347,  
A601005348, A601005349, A601005350, A601005351, A601005352, A601005353,  
A601005354, A601005355, A601005356, A601005357, A601005358, A601005359,  
A601005360, A601005361, A601005362, A601005363, A601005394, A601005395,  
A601005396, A601005397, A601005398, A601005399, A601005400, A601005401,  
A601005402, A601005403, A601005404, A601005405, A601005406, A601005407,  
A601005408, A601005409, A601005410, A601005412, A601005413, A601005414,  
A601005415, A601005416, A601005417, A601005418, A601005419, A601005420,  
A601005421, A601005422, A601005423, A601005424, A601005425, A601005426,



A601005427, A601005428, A601005429, A601005430, A601005431, A601005432,  
A601005442, A601005443, A601005447, A601005448, A601005449, A601005450,  
A601005451, A601005452, A601005453, A601005455, A601005456, A601005458,  
A601005460, A601005461, A601005462, A601005463, A601005464, A601005465,  
A601005466, A601005467, A601005469, A601005470, A601005471, A601005473,  
A601005474, A601005475, A601005476, A601005479, A601005480, A601005482,  
A601005483, A601005484, A601005485, A601005486, A601005488, A601005489,  
A601005490, A601005491, A601005594, A601005595, A601005596, A601005610,  
A601005614, A601005628, A601001016





This page intentionally left Blank.



# MAST WELD REINFORCEMENT

---

**SJ12 E, SJ16 E, SJ20 E**

ANSI/CSA, CE, AS & KC

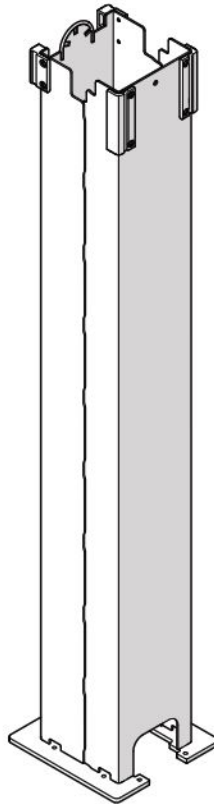

VERTICAL MAST

**248194ABA**

June 2023

**This field kit is for MEWPs with serial numbers:**

**SJ12 E:** A601 000 906 - A601 005 185

**SJ16 E:** A601 000 909 - A601 005 478

**SJ20 E:** A601 000 763 - A601 005 628

**Please refer to the website ([www.skyjack.com](http://www.skyjack.com)) for contact information, other serial numbers, the most recent technical manuals, animations, and USB software.**

The original instructions are in English.

---

**THIS SAFETY ALERT SYMBOL MEANS ATTENTION!**



**BE ALERT! YOUR SAFETY IS INVOLVED.**

The Safety Alert Symbol identifies important safety messages on MEWPs, safety signs in manuals or elsewhere. When you see this symbol, be alert to the possibility of personal injury or death. Follow the instructions in the safety message.

** DANGER**

---

**DANGER** indicates an imminently hazardous situation which, if not avoided, will result in death or serious injury.

---

** WARNING**

---

**WARNING** indicates a potentially hazardous situation which, if not avoided, could result in death or serious injury.

---

** CAUTION**

---

**CAUTION** indicates a potentially hazardous situation which, if not avoided, may result in minor or moderate injury. It may also be used to alert against unsafe practices.

---

**IMPORTANT**

**IMPORTANT** indicates a procedure essential for safe operation and which, if not followed, may result in a malfunction or damage to the equipment.



---

# Table of Contents

<b>Section 1 – Before You Start</b> .....	<b>6</b>
<b>1.1 Machine Preparation</b> .....	<b>6</b>
<b>1.2 Assembly/disassembly tools and material needed</b> .....	<b>6</b>
<b>1.3 Weld tools and materials needed</b> .....	<b>6</b>
<b>Section 2 – Procedures</b> .....	<b>7</b>
<b>2.1 Remove the platform, base cover, and mast</b> .....	<b>7</b>
2.1-1 <i>Disconnect the electrical components at the platform</i> .....	7
2.1-2 <i>Remove the platform</i> .....	9
2.1-3 <i>Remove the load cells</i> .....	11
2.1-4 <i>Disconnect the electrical components at the base and mast</i> .....	11
2.1-5 <i>Disconnect the lift cylinder</i> .....	14
2.1-6 <i>Remove the mast</i> .....	16
<b>2.2 Reinforce the mast weld</b> .....	<b>18</b>
2.2-1 <i>Weld overview diagram for SJ12 E</i> .....	19
2.2-2 <i>Reinforce the mast weld - SJ12 E</i> .....	20
2.2-3 <i>Weld overview diagram for SJ16 E</i> .....	23
2.2-4 <i>Reinforce the mast weld - SJ16 E</i> .....	24
2.2-5 <i>Weld overview diagram for SJ20 E</i> .....	27
2.2-6 <i>Reinforce the mast weld - SJ20 E</i> .....	28
<b>2.3 Touch up the paint</b> .....	<b>30</b>
<b>2.4 Install the mast, base cover, and platform</b> .....	<b>31</b>
2.4-1 <i>Assemble the mast</i> .....	31
2.4-2 <i>Install the mast</i> .....	34
2.4-3 <i>Base electrical connections</i> .....	36
2.4-4 <i>Install the base cover</i> .....	38
2.4-5 <i>Install the platform</i> .....	39
<b>Section 3 – Testing</b> .....	<b>43</b>

# Section 1 – Before You Start

## **WARNING**

Only qualified and authorized personnel shall be permitted to install or service this equipment.

## **WARNING**

Read all instructions closely before attempting each step of the procedure.

## **WARNING**

All welding must be done by a welder qualified for manual metal arc welding (MMA or MMAW) or shielded metal arc welding (SMAW) steel in a horizontal welding position for fillet welds (FW).

## 1.1 Assembly/disassembly tools and material needed

- The items listed below must be capable of lifting and supporting 680 kg (1500 lb):
  - Suitably rated lifting device with 4.5 m (15 ft) lifting height
  - Lifting straps or chains
  - Hoist rings or hooks for 7 mm (9/32") holes
  - Four support stands or four blocks of wood at least 30 cm (12") long
- Standard ratchet/wrench set
- Standard screwdriver set
- Rivet gun
- Two rivets size 4 mm x 8 mm (5/32" x 5/16")
- Four rivets size 5 mm x 14 mm (3/16" x 9/16")
- Power drill or chisel (to remove rivets)
- Cutters
- Size 06 JIC female fitting cap
- Size 06 JIC male hose end plug
- Size 08 ORB male plug
- Container to catch hydraulic oil
- Rags
- Cable ties
- Black paint
- Bolt, approximately 8 mm x 65 mm (3/8"-16 x 2-1/2") and nut, class 10.9 (grade 8)
- Medium-strength threadlocker, similar to blue Loctite 242

## 1.2 Weld tools and materials needed

- Weld table/work surface
- Sanding disc (24 grit)
- MMA/SMAW welding system
- E7018 weld electrodes, 0.5 kg (1 lb)
- Air blow gun
- Chipping hammer
- Steel chisel, 3 cm (1-1/4")
- Work light or flashlight
- Ruler (metric/imperial) or vernier calipers
- Wire brush, cup style
- Grinder with an abrasive grinding disc, 110 mm x 3 mm x 20 mm (4-1/2" x 1/8" x 7/8")

## 1.3 Machine Preparation

1. Park the MEWP on a firm level surface.
2. Push in the emergency stop button on the base.
3. Turn the off/platform/base key switch to the off position and remove the key.
4. Turn the main power disconnect switch to the off position.

# Section 2 – Procedures

## 2.1 Remove the platform, base cover, and mast

### 2.1-1 Disconnect the electrical components at the platform

1. Remove and set aside the mast cover and hardware.

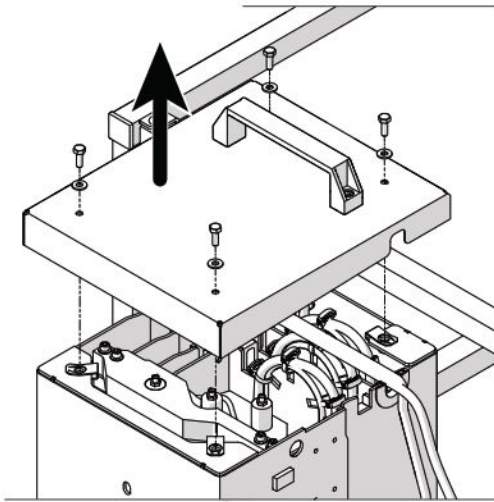

2. Extend the platform at least 30 cm (12").

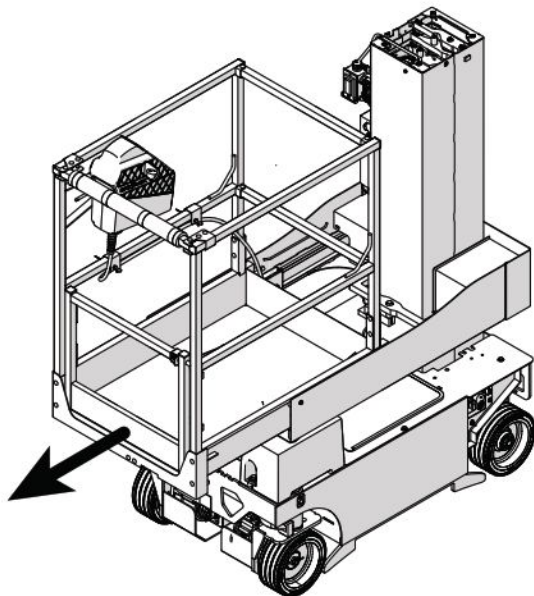

3. Put a long cable tie around the sides of the upper and lower platforms, through a slot in the upper platform near the railings. Do this on both the left and right sides to secure the platform from moving.

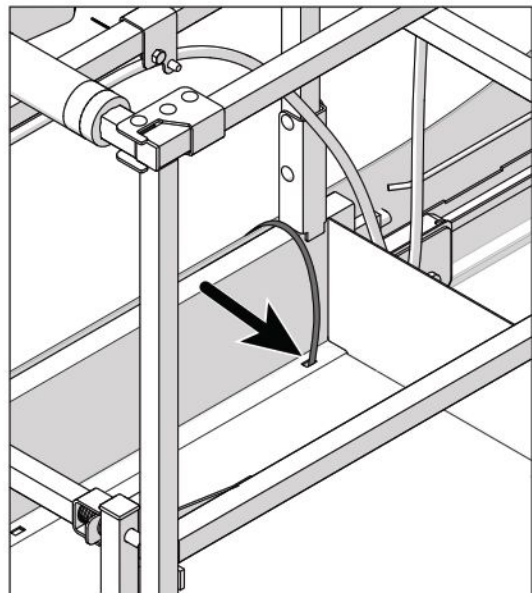
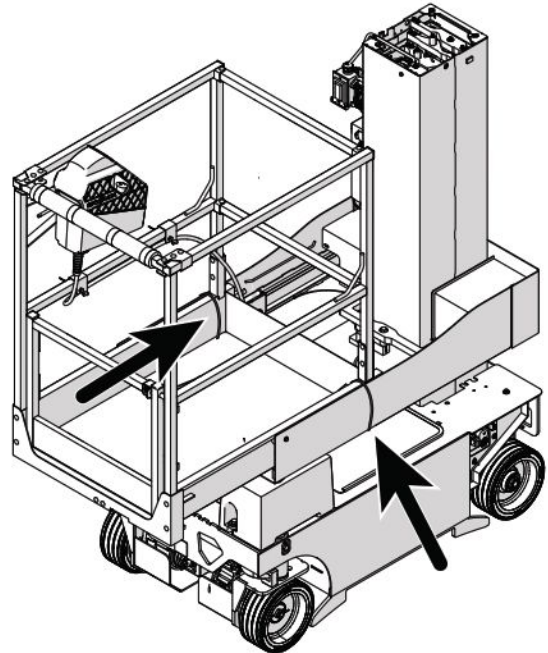



4. Disconnect the platform control cable from the mast electrical housing.

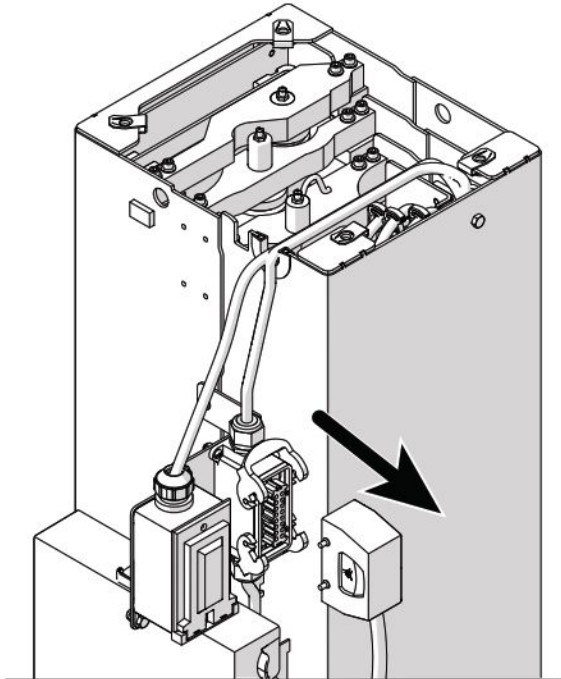

5. If the mast electrical housing is attached directly to the side of the mast as shown below, remove it from the mast for easier access. If it's mounted on a bracket at the front it can stay in place.

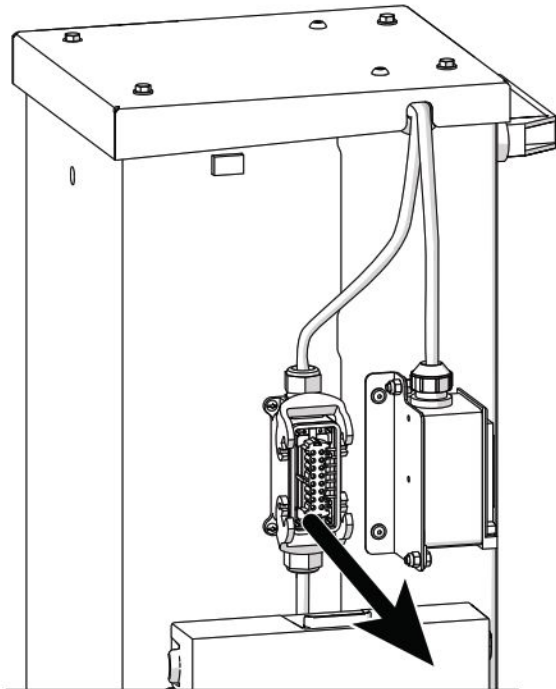

6. Loosen the lower strain relief on the housing.
7. Use a screwdriver to open the housing so you can see the wire connections.
8. Disconnect the limit switch wires from the housing.
  - Disconnect the service position limit switch black wire 7 from position 7.
  - Disconnect the service position black/white wire spade connector from the purple/white wire spade connector on the deck extend limit switch.
  - Disconnect the deck extend limit switch black wire 6 from position 6.
  - Disconnect the deck extend limit switch black/white wire 5 from position 5.
9. Pull the limit switch cables out of the housing. Set them in the platform.

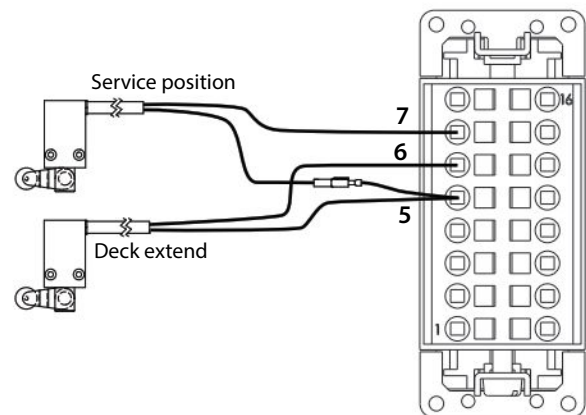
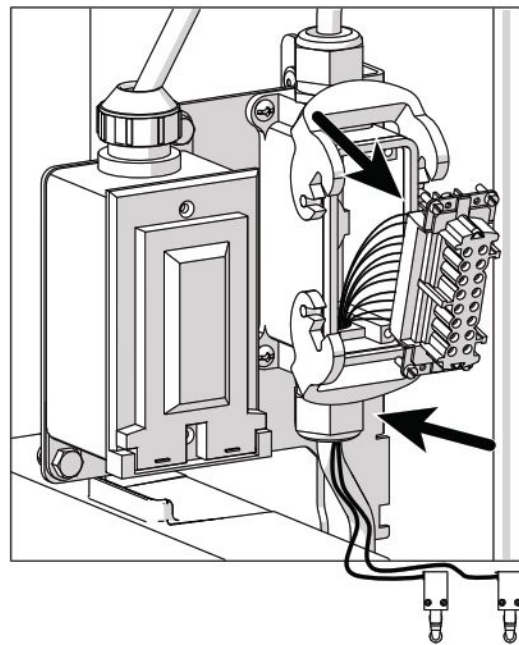

10. Disconnect the mast cable from the load cell module cable.

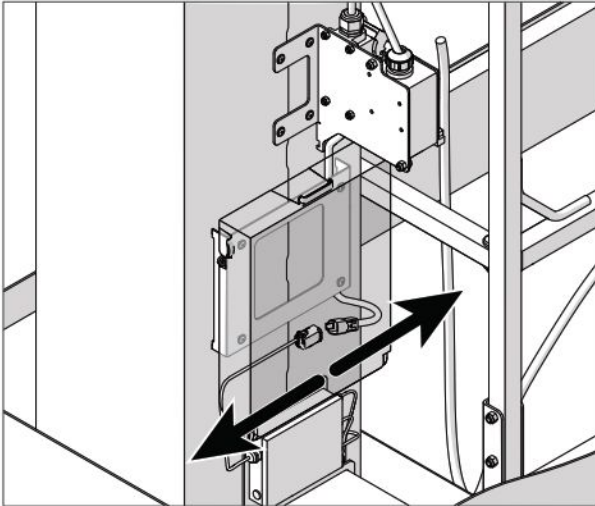

11. Remove and set aside the hardware from the load cell module.
12. Put the load cell module on the chassis.

**IMPORTANT**

Handle the load cell module and load cells carefully as they are very easily damaged.

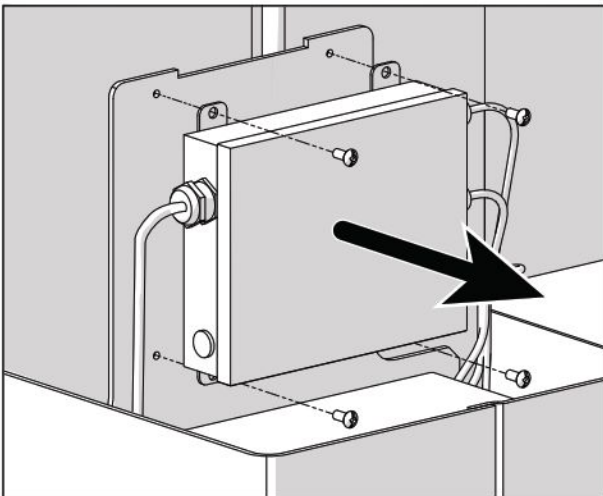

**2.1-2 Remove the platform**

1. Attach the platform to a suitably rated lifting device.

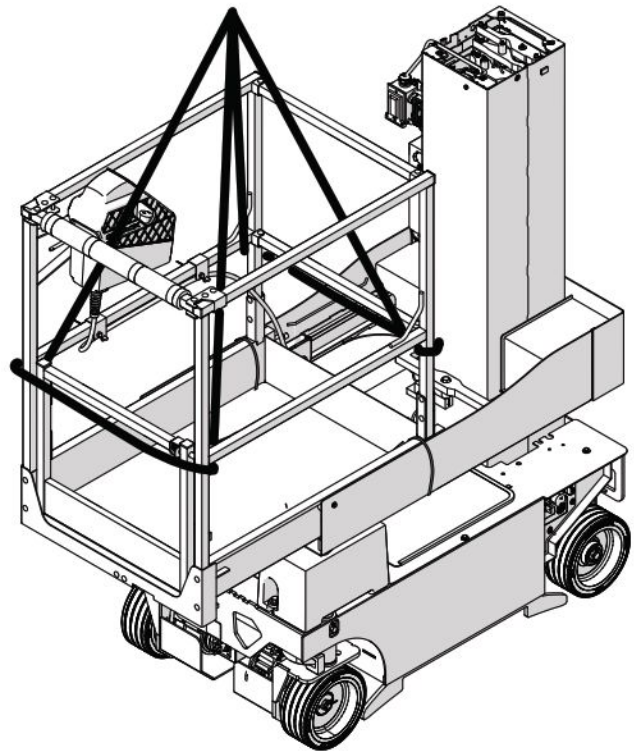

2. Remove the bolt and washer from the link weldment.

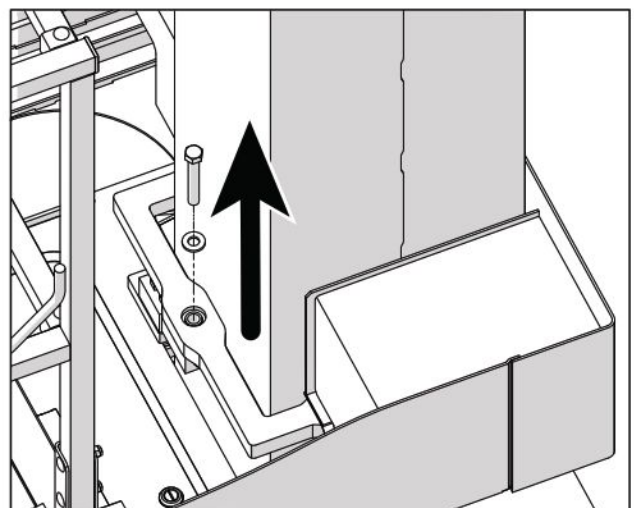

- 3. Remove the bolts and nuts that secure the platform to the mast (three on each side).

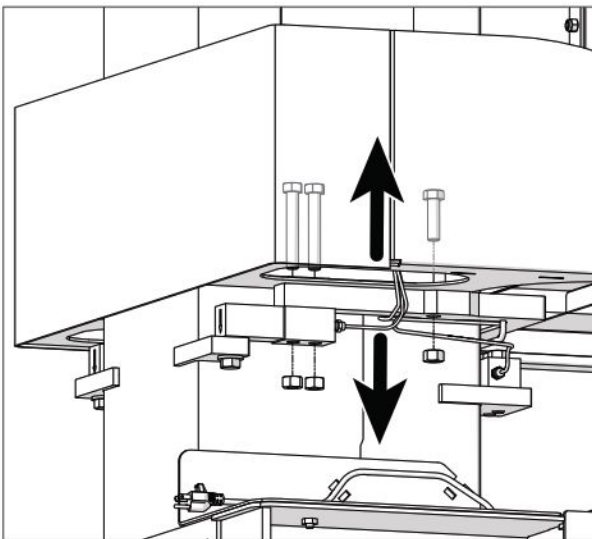
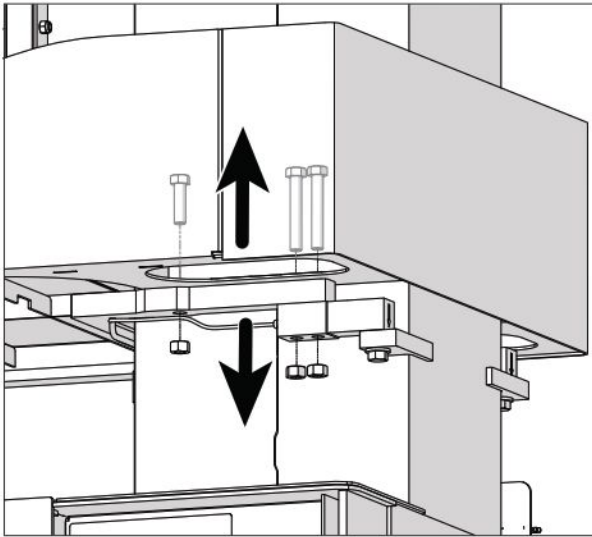

- 4. Start to lift the platform, then push it toward the mast a little to clear the electrical boxes on the mast.
- 5. Continue lifting the platform up and over the mast.
- 6. Set the platform on a protective surface on the floor.

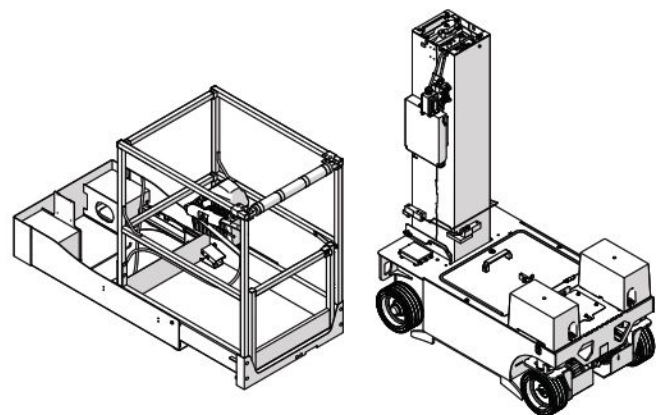
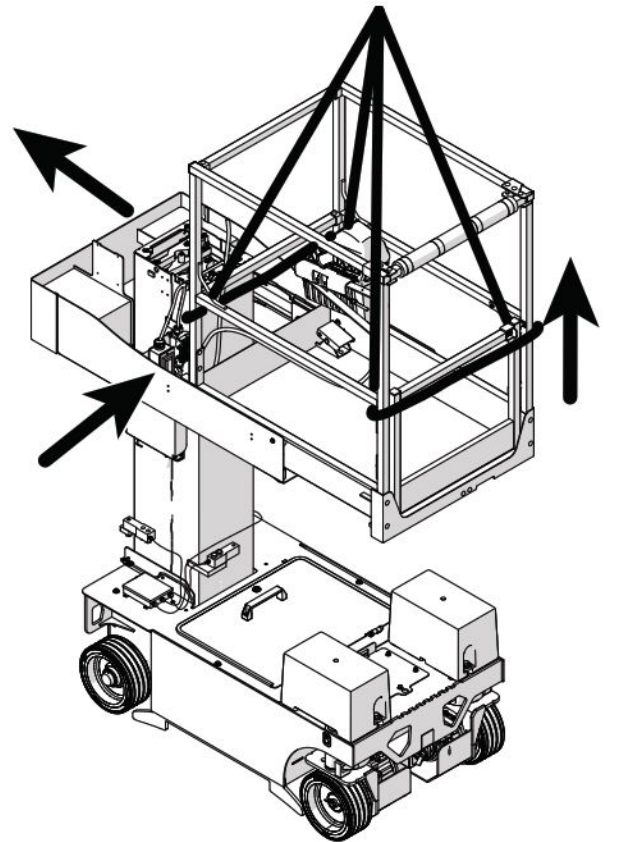

### 2.1-3 Remove the load cells

#### **IMPORTANT**

Handle the load cell module and load cells carefully as they are very easily damaged.

1. Set aside the link weldment and spacer.
2. Remove and set aside the bolts, washers and spacers from the three load cells.
3. Set aside the load cells and load cell module.

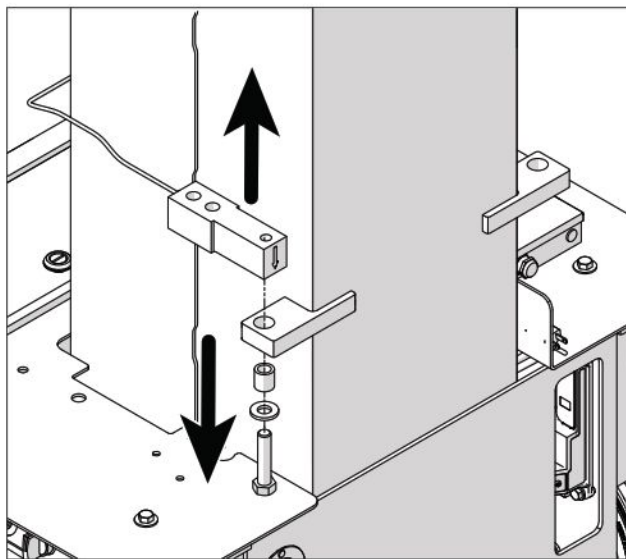
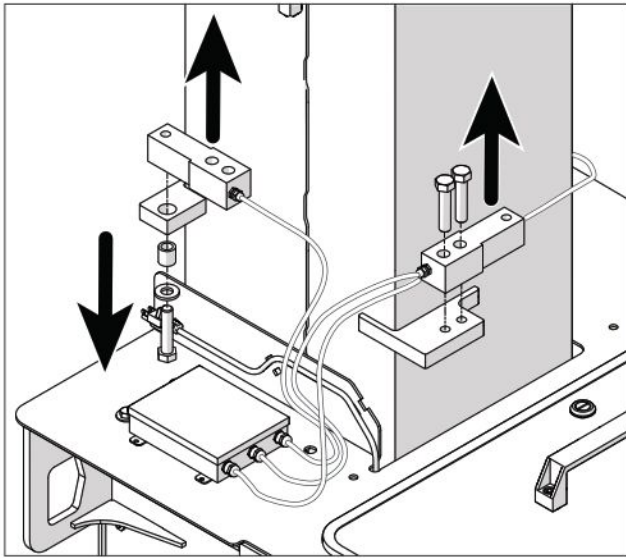

### 2.1-4 Disconnect the electrical components at the base and mast

1. Cut the cable ties that secure the battery charger cable to the base cover.
2. Pull the charger cable out of the base cover grommet. Tuck the cable into the base.

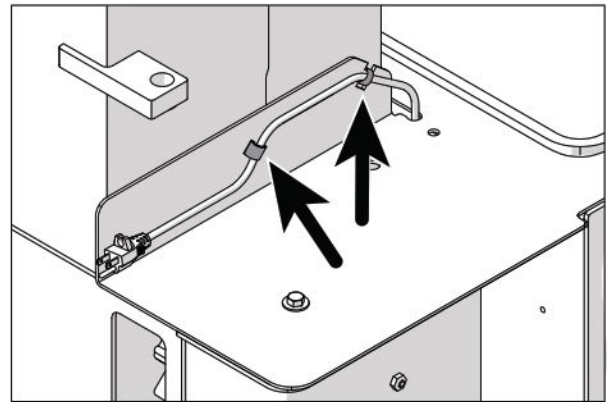

3. Open the base cover.
4. Disconnect the flashing light(s), white noise alarm, and Elevate keypad, if equipped. Remove the Elevate keypad from the bracket.
5. Cut all cables ties securing electrical cables to the base cover.

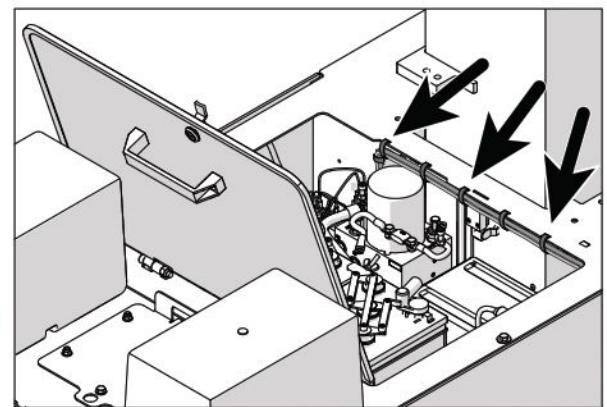



- 6. Remove the hardware securing the base cover.
- 7. Remove and set aside the base cover.

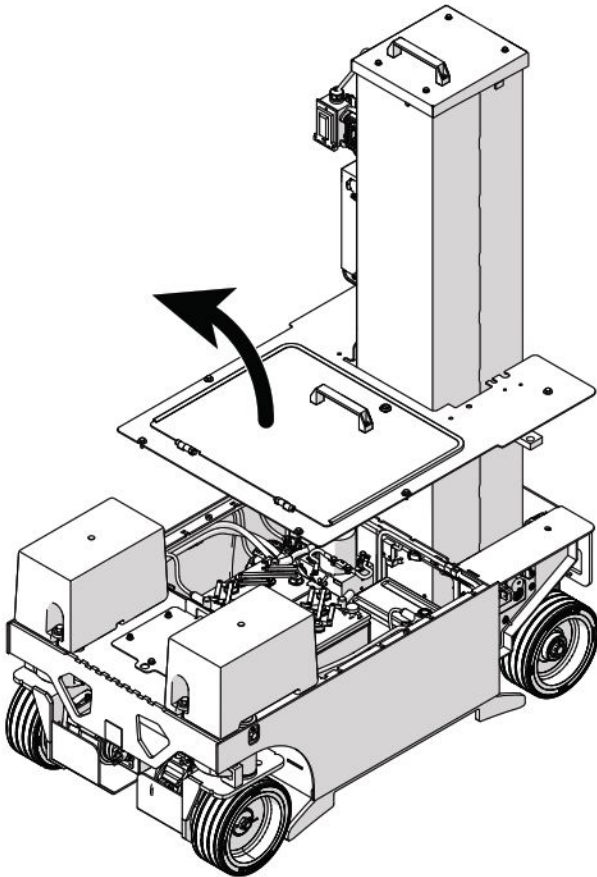

- 8. Disconnect the mast cable from the main harness.
- 9. Cut cable ties along the cable bundles to free the mast cable.

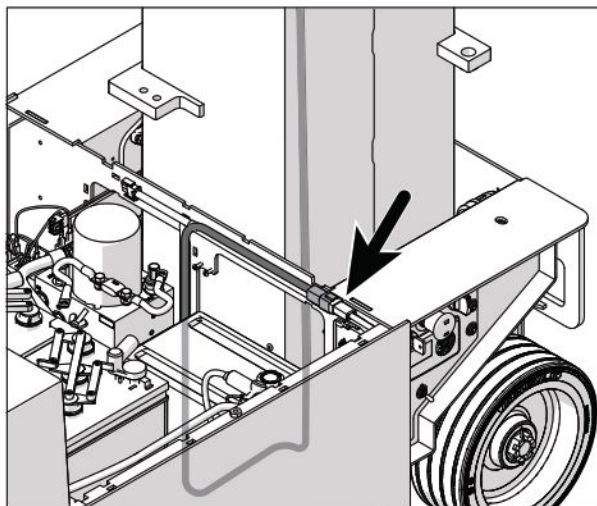

**Note:** the AC plug differs from region to region. The ANSI/CSA version is shown below.

- 10. Remove the rivets that secure the AC plug to the chassis.

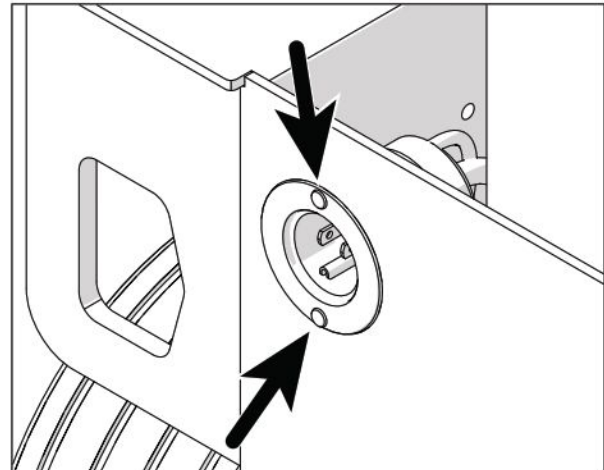

- 11. Pull out the AC plug.
- 12. Disconnect the wires from the back of the plug.

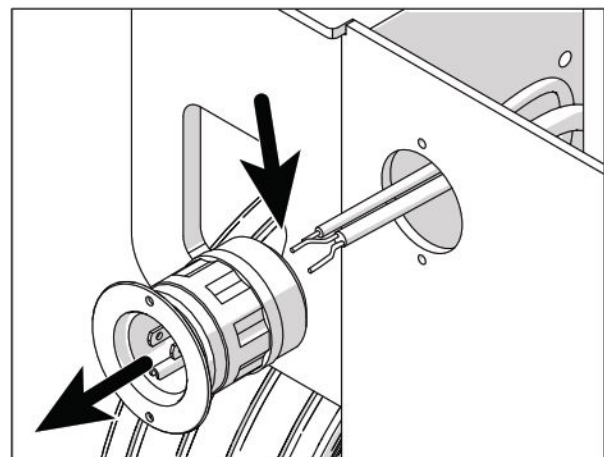

- 13. Cut the cable ties that secure the AC power cable to the cable carrier and existing cable bundles.

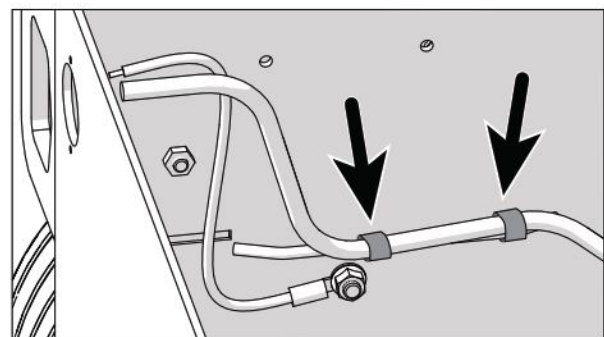

14. Go to the top of the mast. Insert a long bolt (approximately 8 mm x 65 mm, class 10.9 (3/8"-16 x 2-1/2", grade 8)) and nut through the holes in the rear faces of the masts. Make sure it goes through all of the masts.

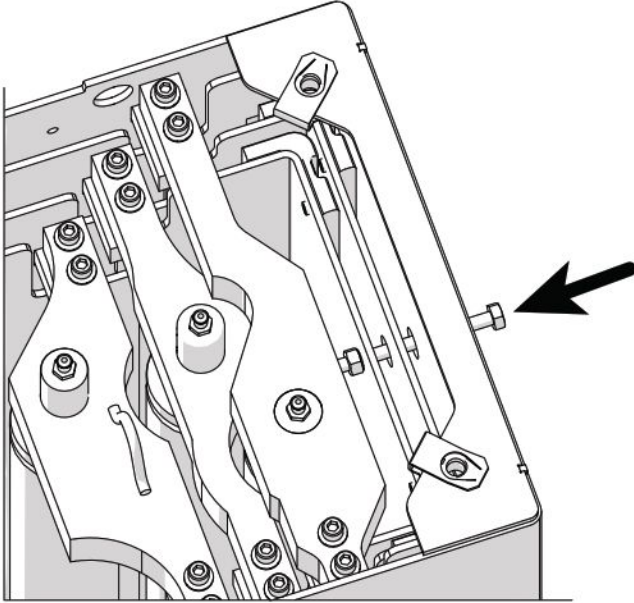

15. Remove the three clips or cut the three cable ties which hold the mast cable and power cable to the innermost mast.

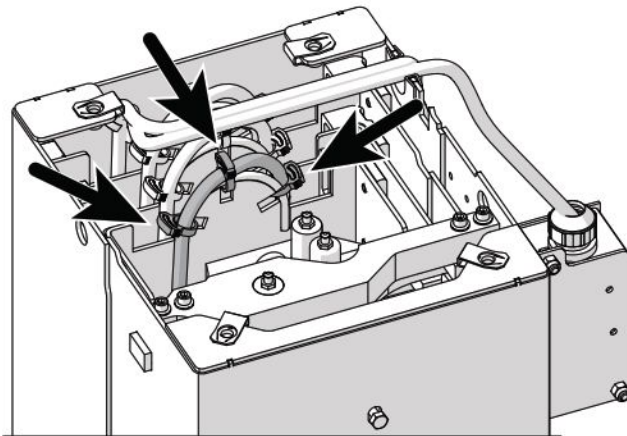

16. Pull the mast cable and power cable up and out of the mast. The cable weight will drop down into the mast.
17. Coil the cables together around the cable connector box on the mast. Secure them with a cable tie.

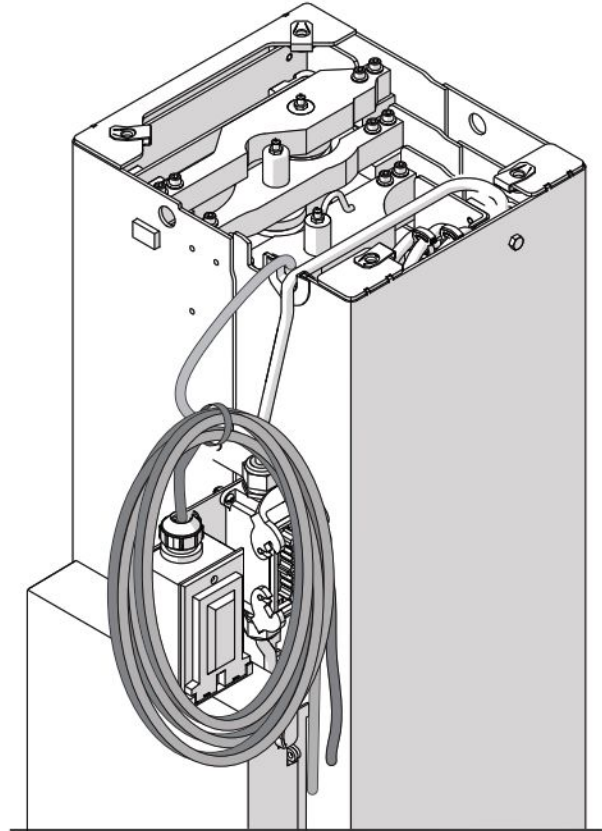

### 2.1-5 Disconnect the lift cylinder

1. Connect a suitably rated lifting device to the top of the mast. Raise it just until the slack in the straps or chains is gone.

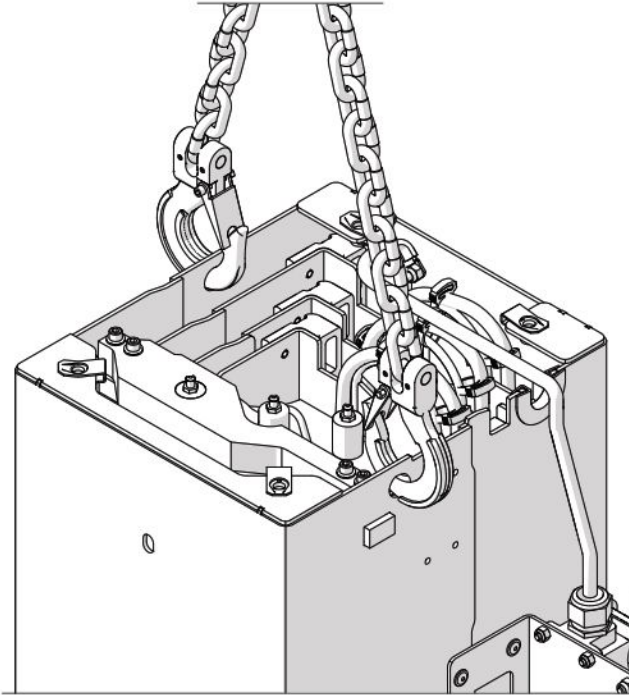

2. Disconnect the harness from the holding valve.

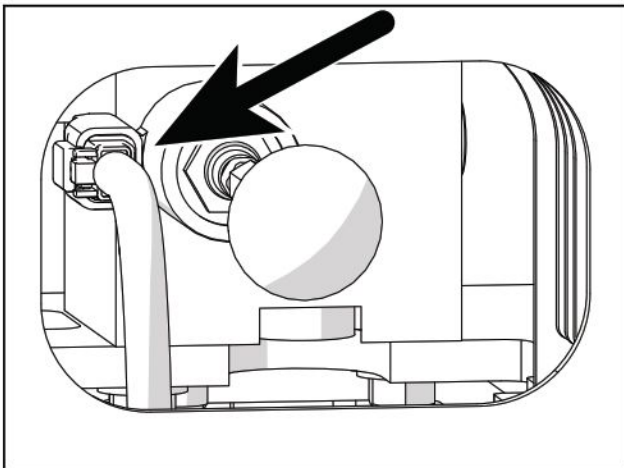

3. Remove and set aside the red knob and hex standoff from the emergency lowering valve. Hold the valve shaft with a wrench to keep it from turning when you remove the hex standoff.

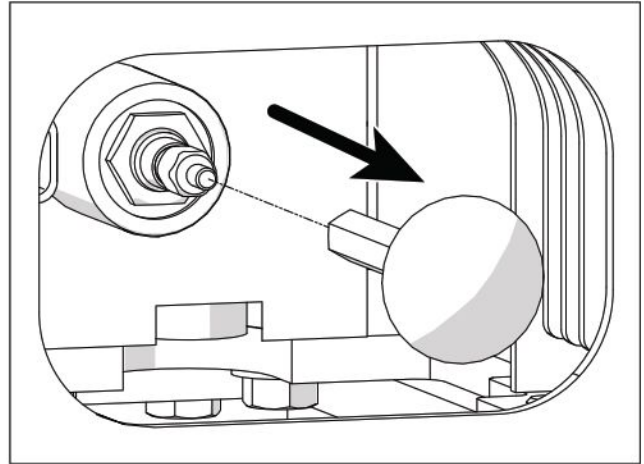

4. Remove the coil nut and coil from the valve.

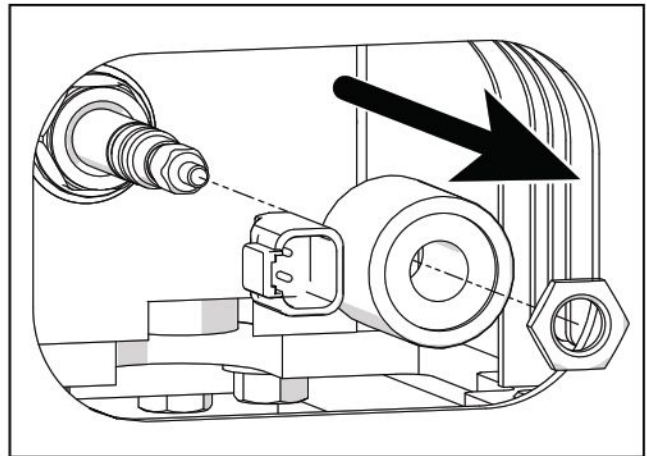

5. Remove the valve. Plug the manifold. Set the valve aside someplace clean where it will not be contaminated.

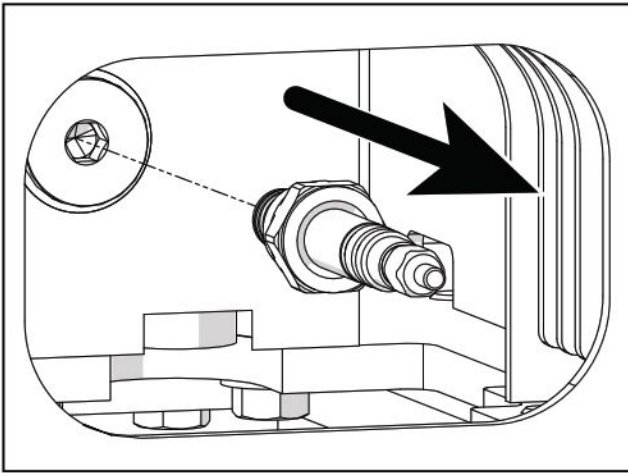

7. Place a pan below the chassis, under the mast.
8. From the underside of the chassis, disconnect the hydraulic hose from the bottom of the emergency lowering valve manifold. Cap or plug the hose end and hydraulic fitting.

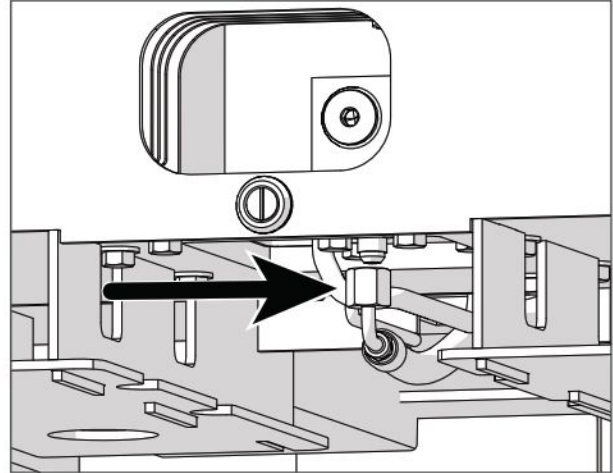

6. Remove the EcoTray, if equipped.

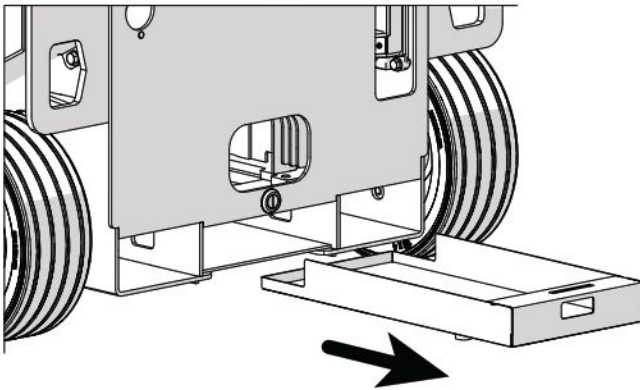



### 2.1-6 Remove the mast

1. Remove and set aside the eight sets of bolts and washers that secure the mast to the chassis.

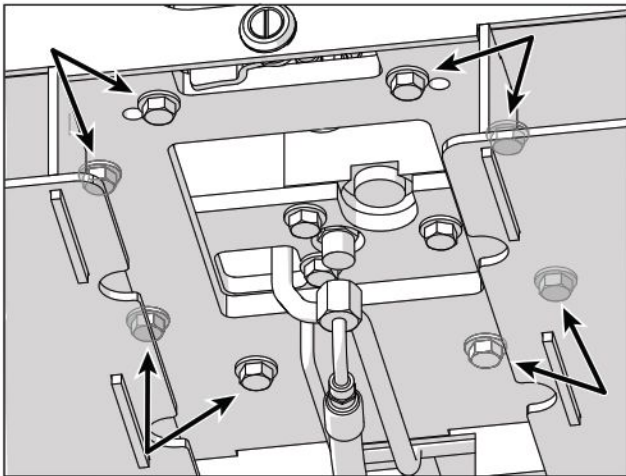

2. Place two support stands or two blocks of wood on the floor.
3. Use a suitably rated lifting device to lift the mast above the chassis.
4. With the e-lowering valve cutout facing down, lay the mast horizontally on the supports or blocks.

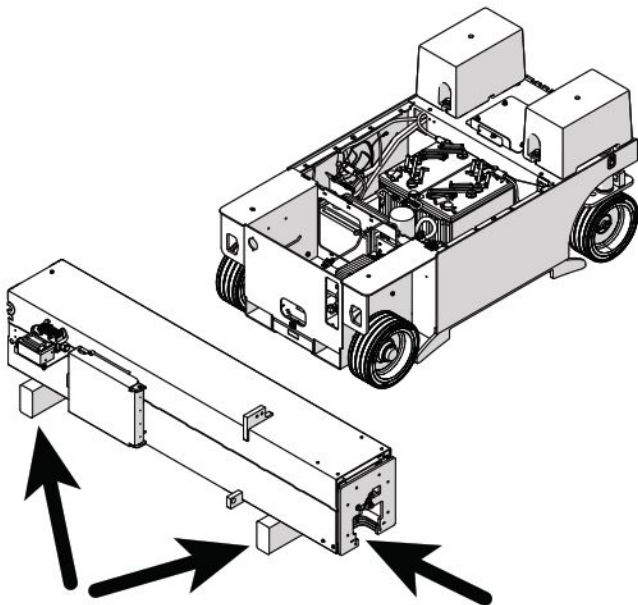

5. Remove and set aside the three sets of hardware that secures the lift cylinder to the bottom of the chassis.

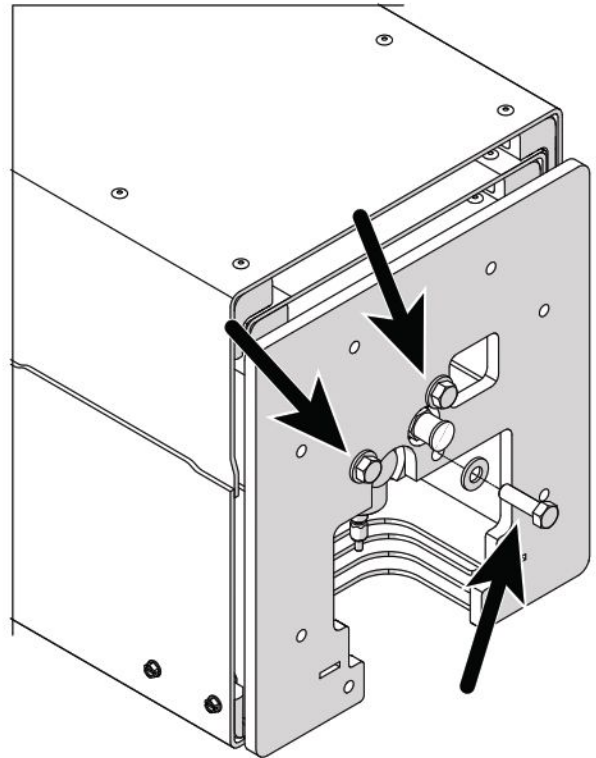

6. Remove and set aside the four bolts that secure the lift cylinder to the top of the innermost mast.

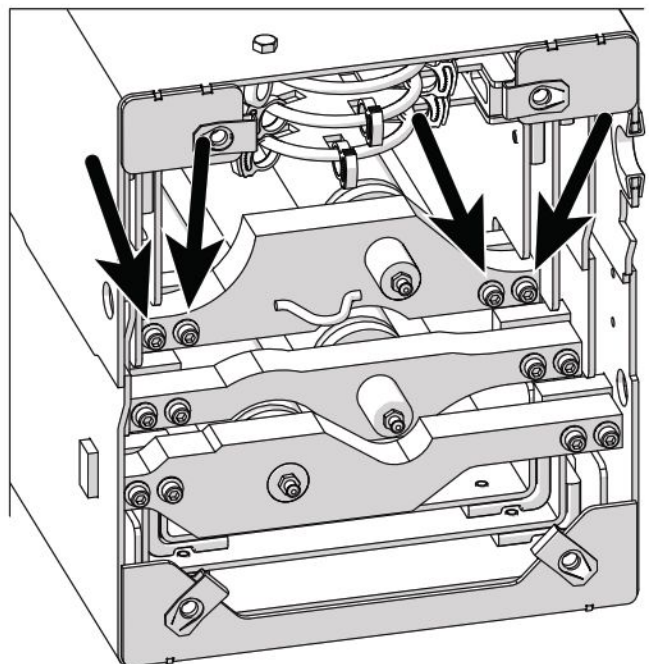

7. Remove the nut and bolt you installed earlier through all of the masts at the top.

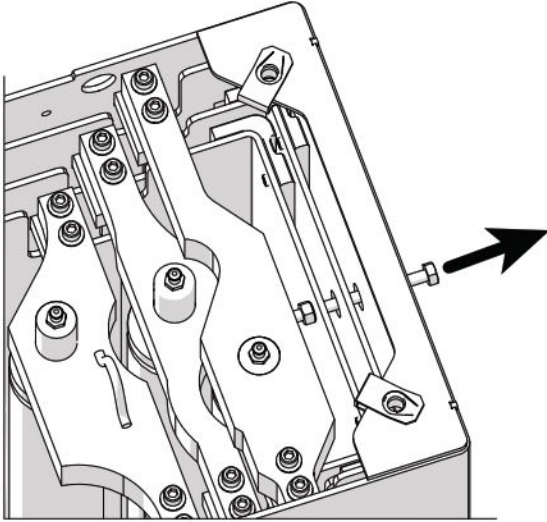

8. Slide out the innermost mast until the next mast starts to come out as well and you can see four wear pads.
9. Remove the four rivets from the wear pads on top, and the four screws from the wear pads on the bottom.

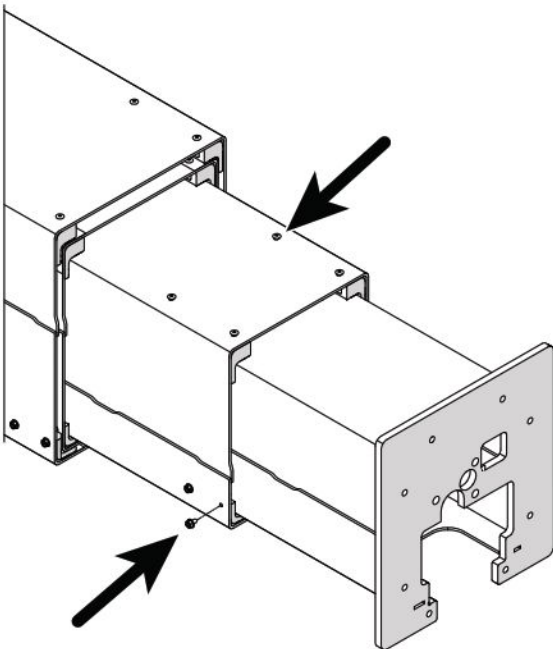

10. Remove and set aside the wear pads.

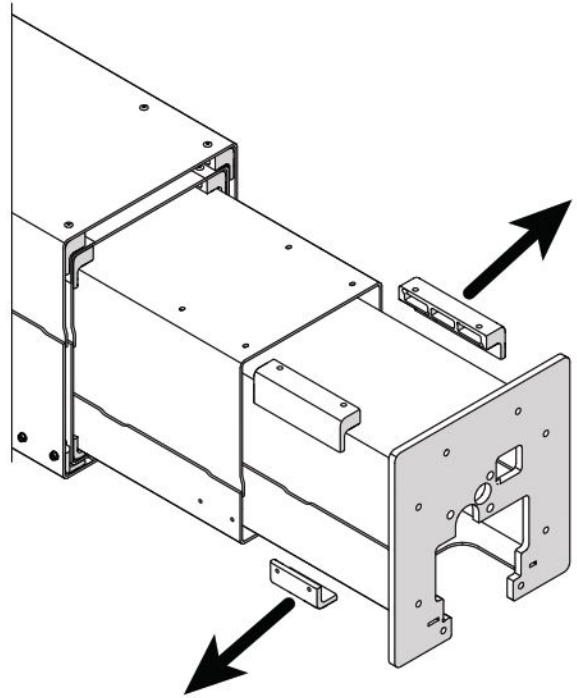

11. Slide the innermost mast out completely and set it on support stands or blocks of wood.
12. Remove and set aside the loose cable weight.

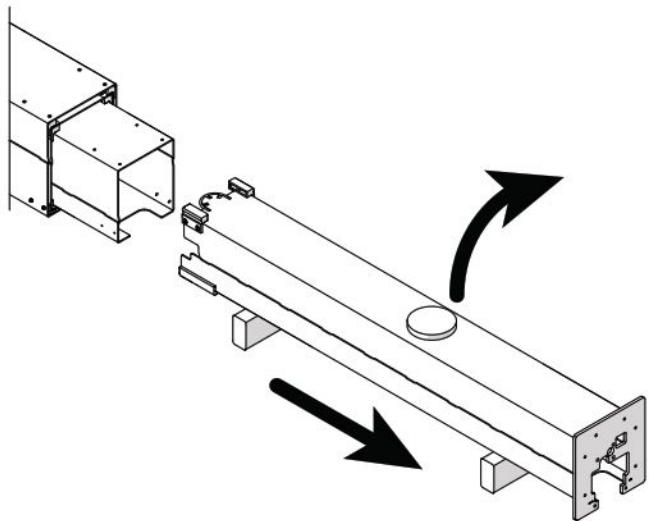

- Take the innermost mast to the area where you are doing the welding and set it in a vertical position.

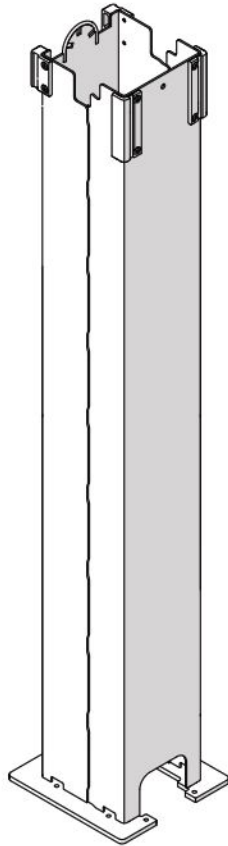

- Clean and inspect all of the hardware you removed in the previous steps. Replace any hardware that is damaged or otherwise not fit for reuse.

## 2.2 Reinforce the mast weld

### **⚠ WARNING**

All welding must be done by a welder qualified for manual metal arc welding (MMA or MMAW) or shielded metal arc welding (SMAW) steel in a horizontal welding position for fillet welds (FW).

Process	Welding Electrode	
	CSA W48	AWS A5
MMA/SMAW	E4918-H4	E7018-H4

For SJ12 E go to [page 19](#).

For SJ16 E go to [page 23](#).

For SJ20 E go to [page 27](#).

*In this section please note that “Rear” refers directionally to the face of the mast with the e-lowering cutout.*

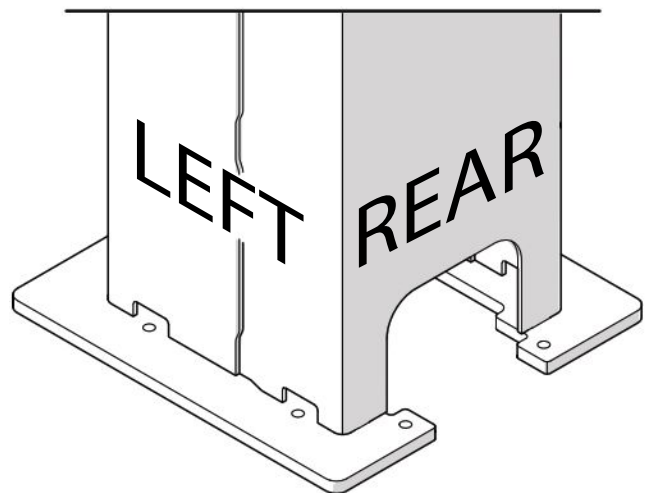

### 2.2-1 Weld overview diagram for SJ12 E

The diagram below is intended to provide a preliminary visual overview of the welds to be done. Detailed instructions on how to do each weld are found in section 2.2-2 Reinforce the mast weld - SJ12 E on page 20.

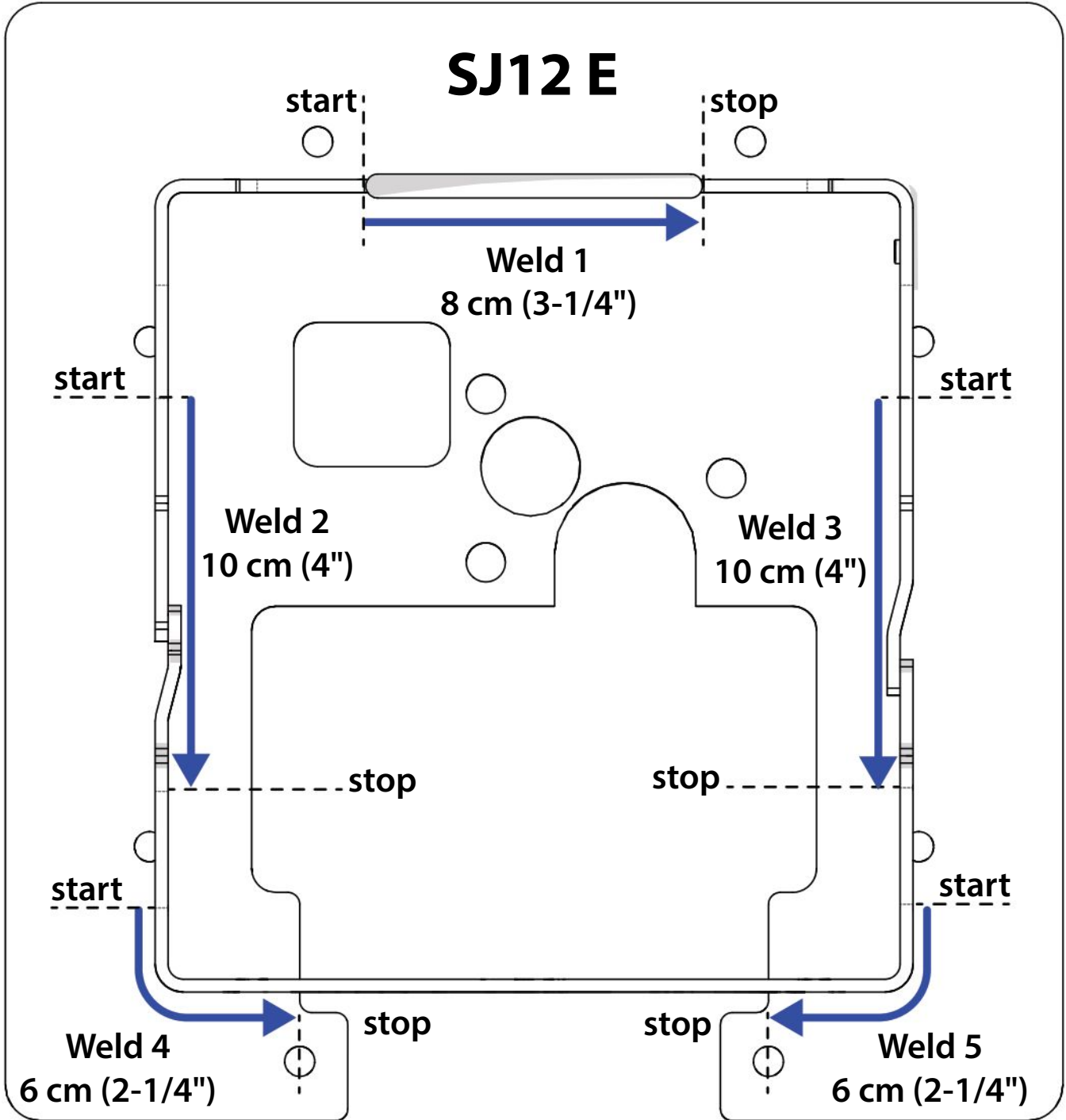

### 2.2-2 Reinforce the mast weld - SJ12 E

Refer to the overview diagram on [page 19](#).

Use E7018 welding rods,  $\varnothing 3 \text{ mm} \times 350 \text{ mm}$  ( $\varnothing 1/8'' \times 14''$ ) to produce 5 mm ( $3/16''$ ) fillet welds for the following steps.

Clean contamination, foreign matter, and paint from the surfaces to be welded.

**Weld 1:** Weld along the inner front face of the mast, between the slots.

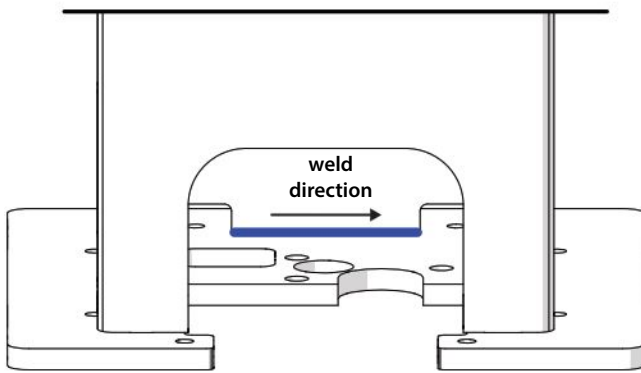

**Weld 2:** Weld along the inner left face of the mast, between the slots.

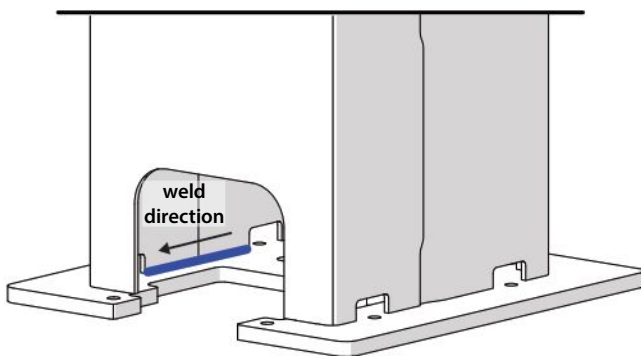

**Weld 3:** Weld along the inner right face of the mast, between the slots.

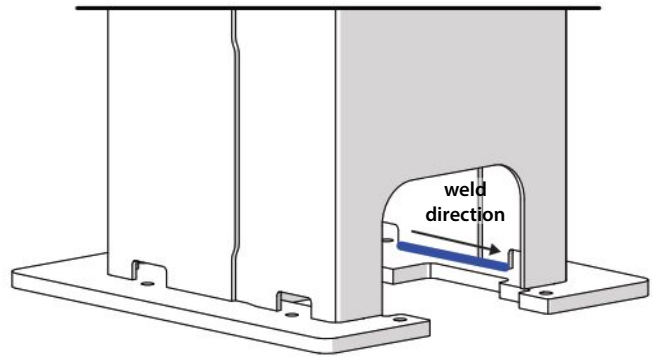

**▲ IMPORTANT**

An accurate grind is critical to ensure good workmanship. Do not leave excessive material of the original weld, and do not grind into the parent material.

**Grind 1:** Use a 3 mm (1/8") thick grinding wheel to grind down the weld along the outer rear left corner of the mast.

- Grind the existing weld to a 5 mm (3/16") preparation as shown below.

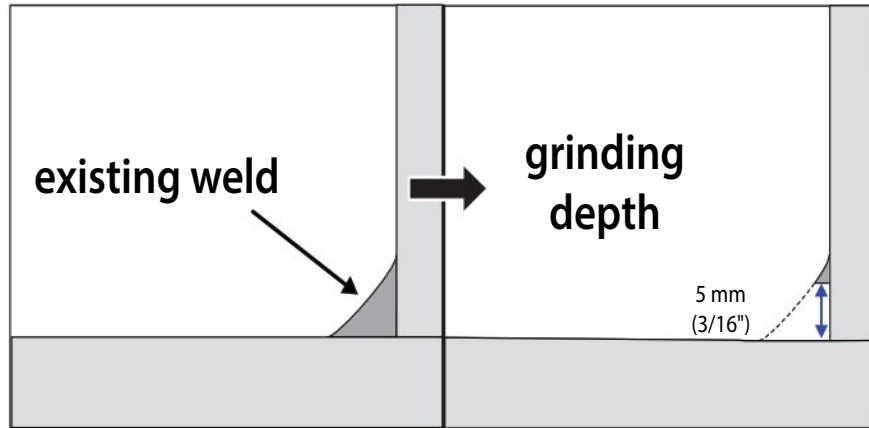

- Grind to 34 mm to 34.5 mm (1.338" to 1.358") in from the rear edge.
- Continue around the corner.
- Grind along the left and stop at the first slot.
- Grind in from the left edge 40 mm to 40.5 mm (1.574" to 1.594").

**Grind 2:** Do the same on the right side.

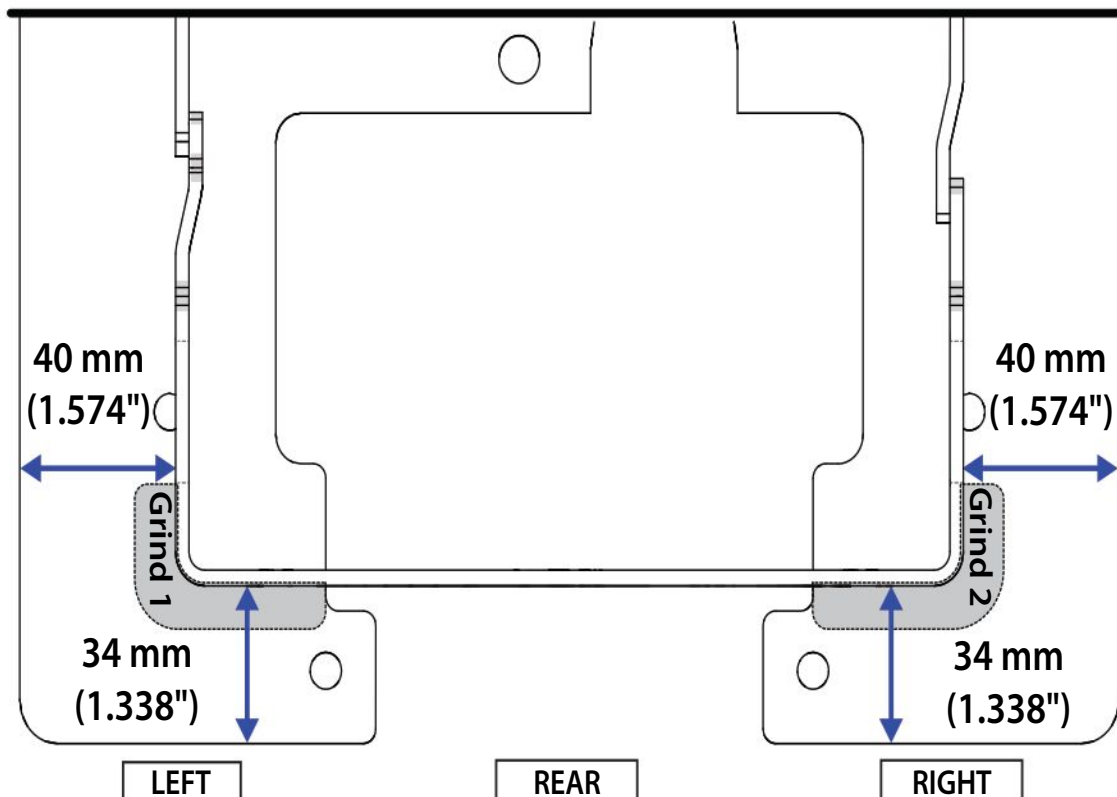

**Weld 4:** Weld along the outer rear left corner of the mast, from the slot to the rear opening.

Go to [2.3 Touch up the paint on page 30](#).

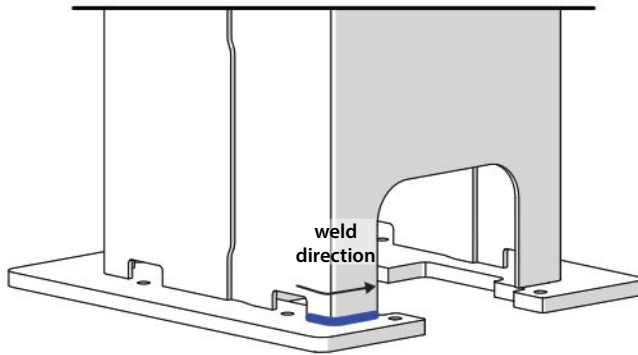

**Weld 5:** Weld along the outer rear right corner of the mast, from the slot to the rear opening.

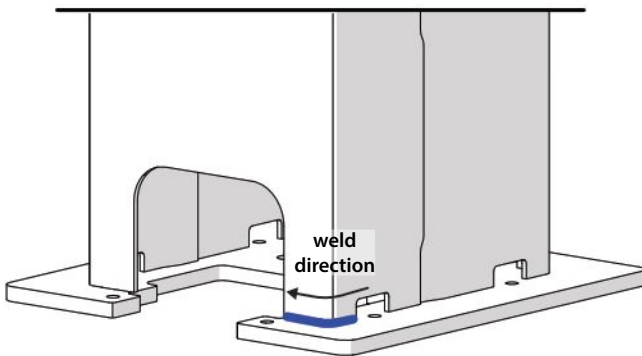

Clean up debris or spatter on the mounting surface inside the mast when the welding is done. See the affected area below.

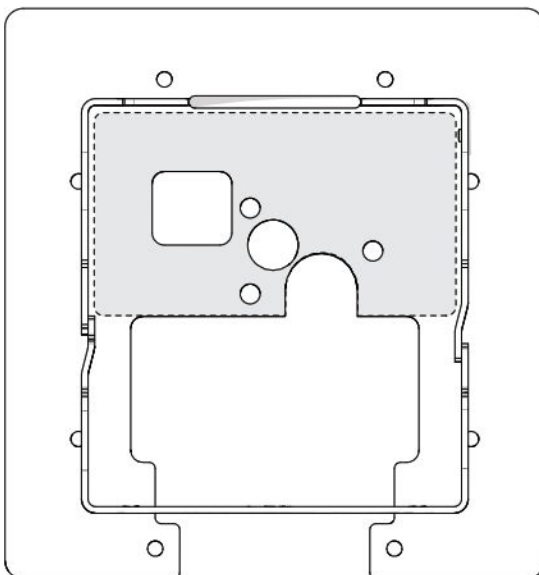



### 2.2-3 Weld overview diagram for SJ16 E

The diagram below is intended to provide a preliminary visual overview of the welds to be done. Detailed instructions on how to do each weld are found in section 2.2-4 Reinforce the mast weld - SJ16 E on page 24.

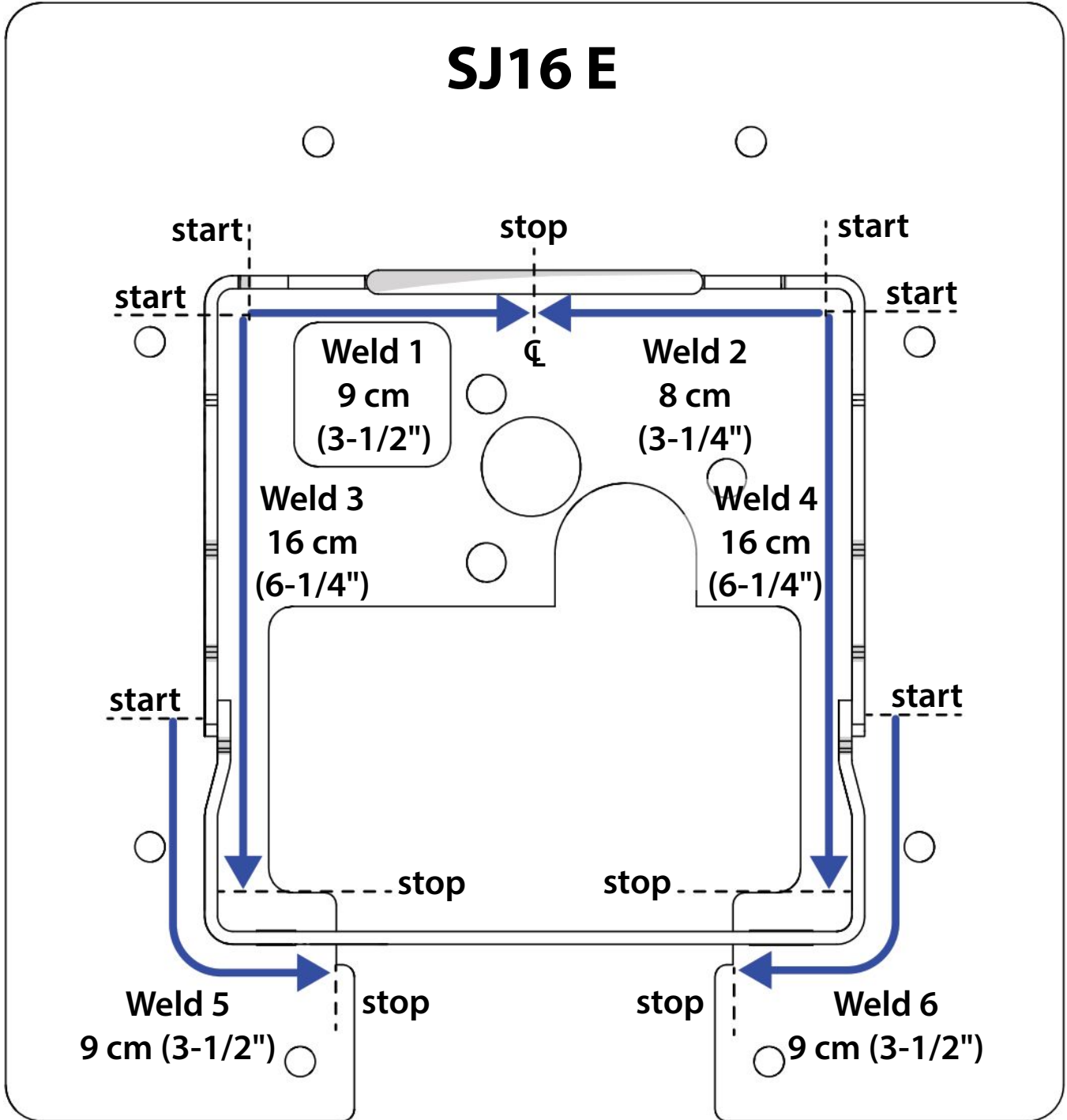



### 2.2-4 Reinforce the mast weld - SJ16 E

Refer to the overview diagram on [page 23](#).

Use E7018 welding rods,  $\varnothing$  3 mm x 350 mm ( $\varnothing$  1/8" x 14") to produce 5 mm (3/16") fillet welds for the following steps.

Clean contamination, foreign matter, and paint from the surfaces to be welded.

**Weld 1:** Weld along the inner left front face of the mast, from the corner almost to the centre.

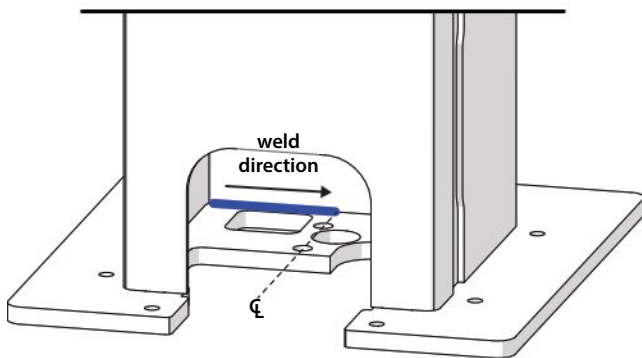

**Weld 2:** Weld along the inner right front face of the mast, from the corner to the centre, connecting with weld 1.

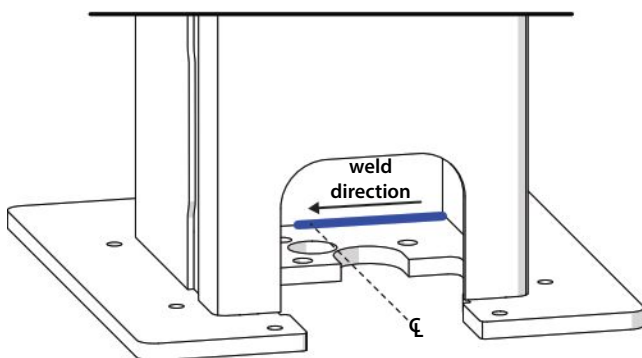

**Weld 3:** Weld along the inner left face of the mast, from the corner to the edge. Refer to the stop location on [page 23](#).

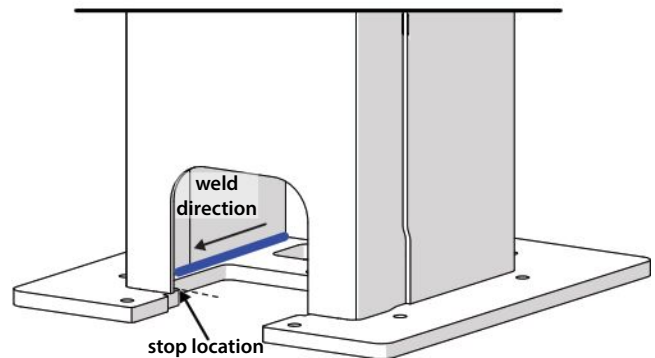

**Weld 4:** Weld along the inner right face of the mast, from the corner to the edge. Refer to the stop location on [page 23](#).

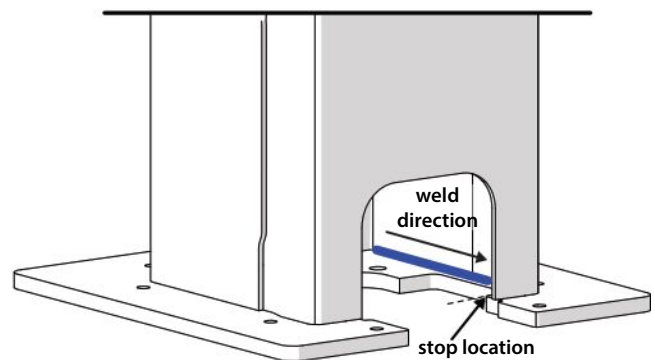

**▲ IMPORTANT**

An accurate grind is critical to ensure good workmanship. Do not leave excessive material of the original weld, and do not grind into the parent material.

**Grind 1:** Use a 3 mm (1/8") thick grinding wheel to grind down the weld along the outer rear left corner of the mast.

- Grind the existing weld to a 5 mm (3/16") preparation as shown below.

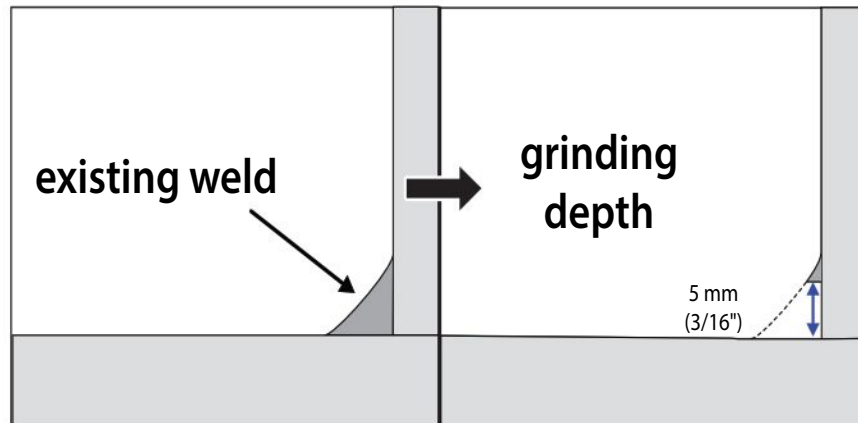

- Grind to 46 mm to 46.5 mm (1.811" to 1.830") in from the rear edge.
- Continue around the corner.
- Grind along the left side for a length of 50 mm (1.969").
- Grind in from the left edge 53 mm to 53.5 mm (2.087" to 2.106").

**Grind 2:** Do the same on the right side.

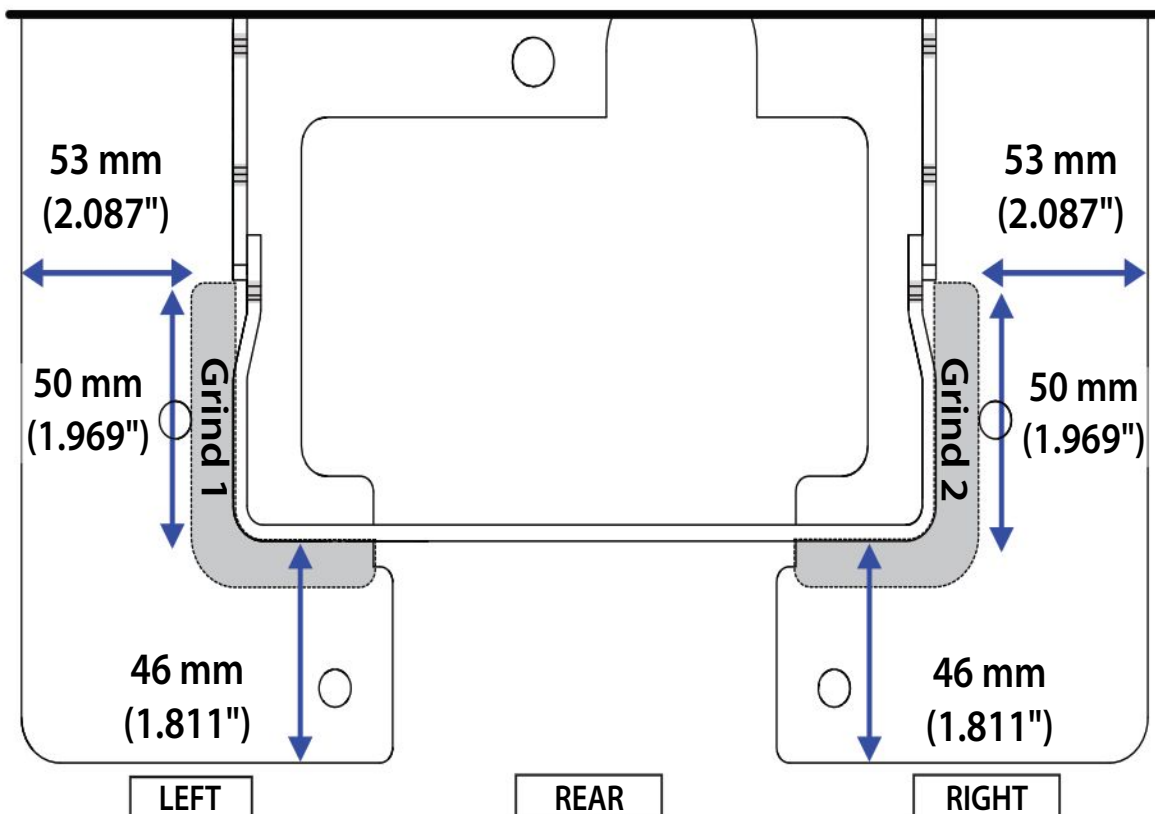

**Weld 5:** Weld along the outer rear left corner of the mast, starting just behind the vertical seam, welding toward the opening.

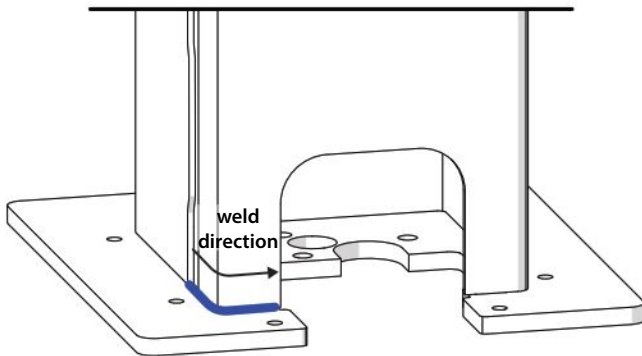

**Weld 6:** Weld along the outer rear right corner of the mast, starting just behind the vertical seam, welding toward the opening.

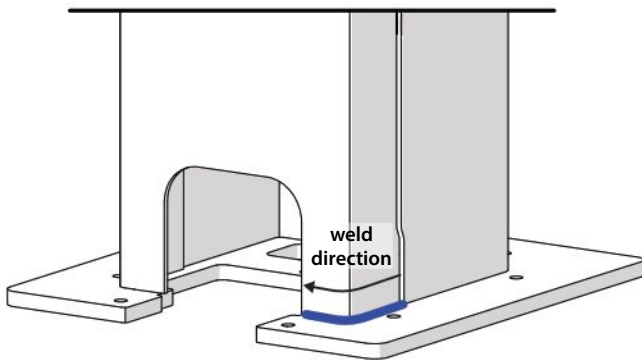

Clean up debris or spatter on the mounting surface inside the mast when the welding is done. See the affected area below.

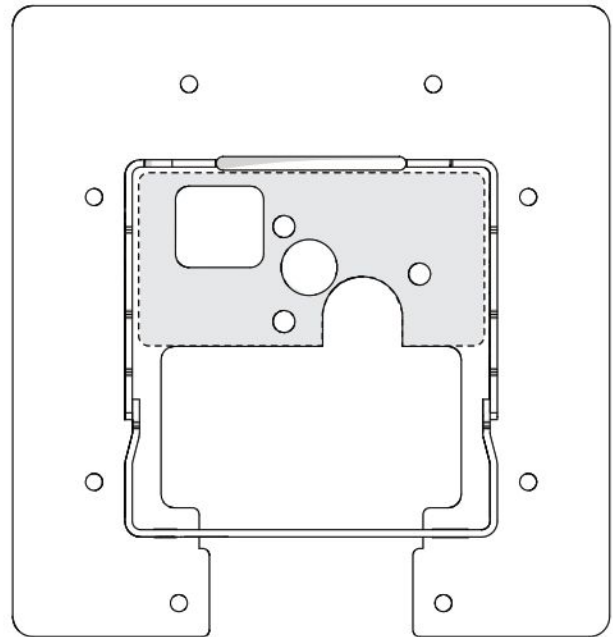

Go to [2.3 Touch up the paint on page 30.](#)

### 2.2-5 Weld overview diagram for SJ20 E

The diagram below is intended to provide a preliminary visual overview of the welds to be done. Detailed instructions on how to do each weld are found in section 2.2-6 Reinforce the mast weld - SJ20 E on page 28.

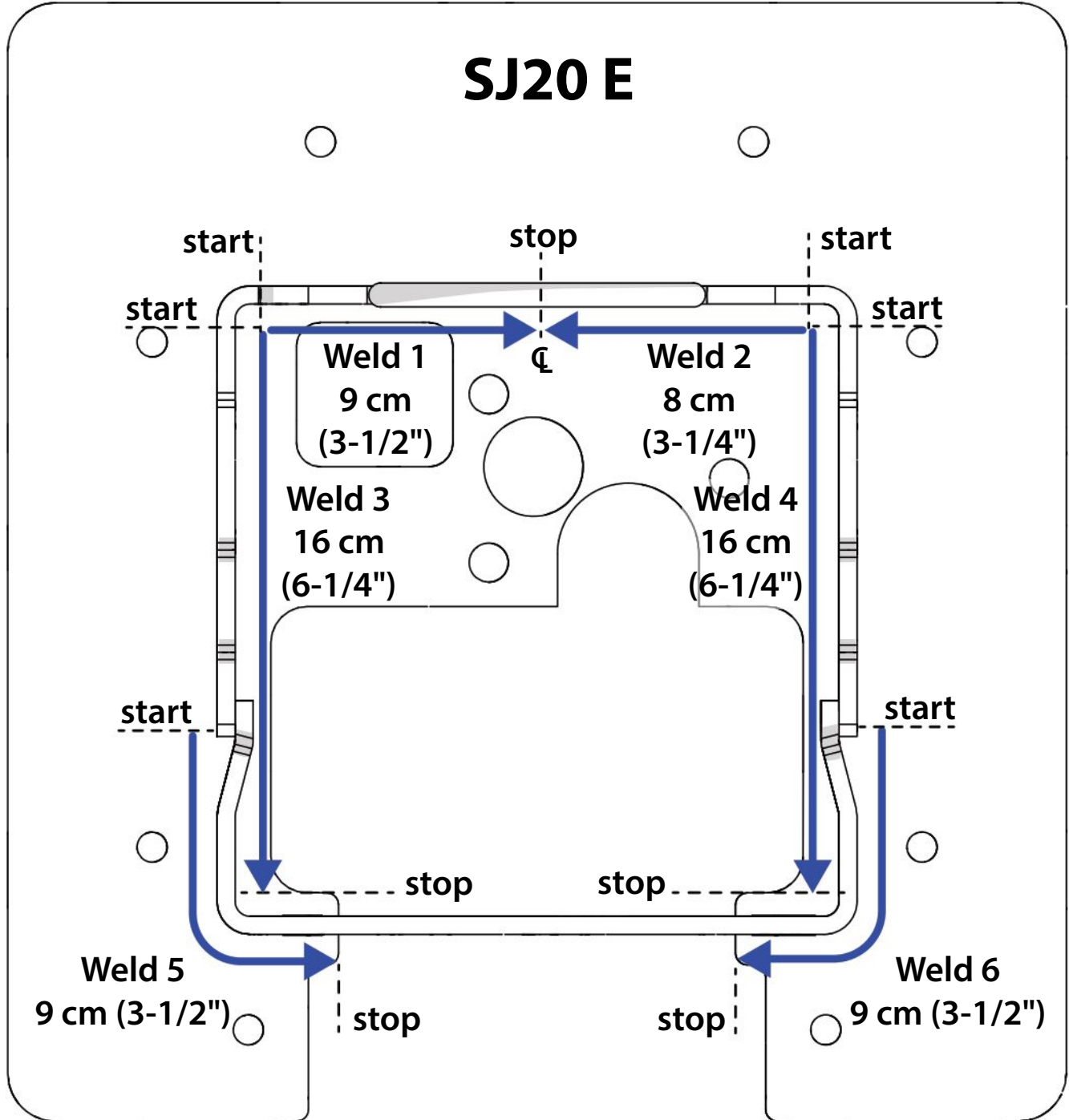

### 2.2-6 Reinforce the mast weld - SJ20 E

Refer to the overview diagram on [page 27](#).

Use E7018 welding rods,  $\varnothing$  3 mm x 350 mm ( $\varnothing$  1/8" x 14") to produce 5 mm (3/16") fillet welds for the following steps.

Clean contamination, foreign matter, and paint from the surfaces to be welded.

**Weld 1:** Weld along the inner left front face of the mast, from the corner to the centre line.

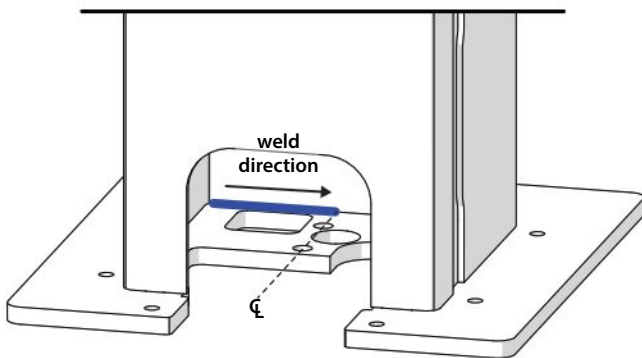

**Weld 2:** Weld along the inner right front face of the mast, from the corner to the centre line, connecting with weld 1.

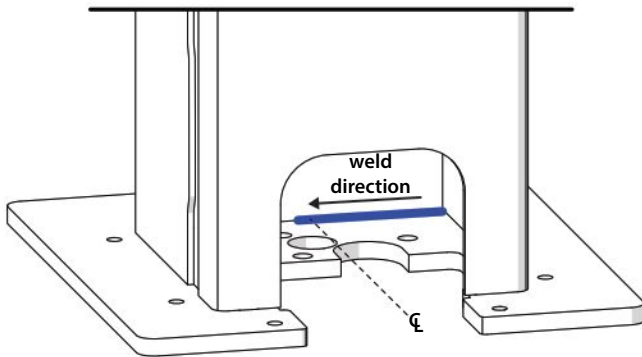

**Weld 3:** Weld along the inner left face of the mast, from the corner to the edge. Refer to the stop location on [page 27](#).

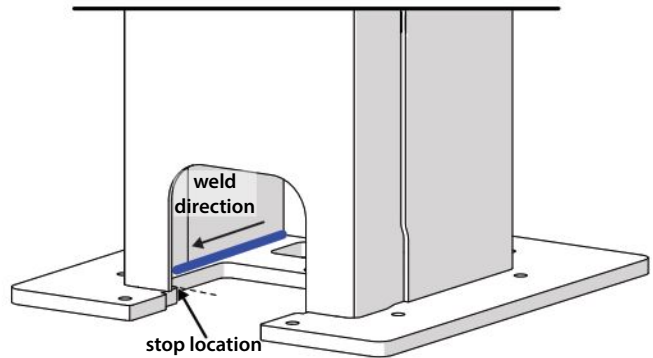

**Weld 4:** Weld along the inner right face of the mast, from the corner to the edge. Refer to the stop location on [page 27](#).

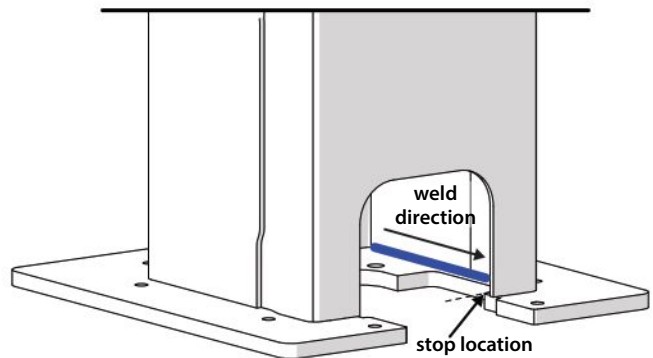

**▲ IMPORTANT**

An accurate grind is critical to ensure good workmanship. Do not leave excessive material of the original weld, and do not grind into the parent material.

**Grind 1:** Use a 3 mm (1/8") thick grinding wheel to grind down the weld along the outer rear left corner of the mast.

- Grind the existing weld to a 5 mm (3/16") preparation as shown below.

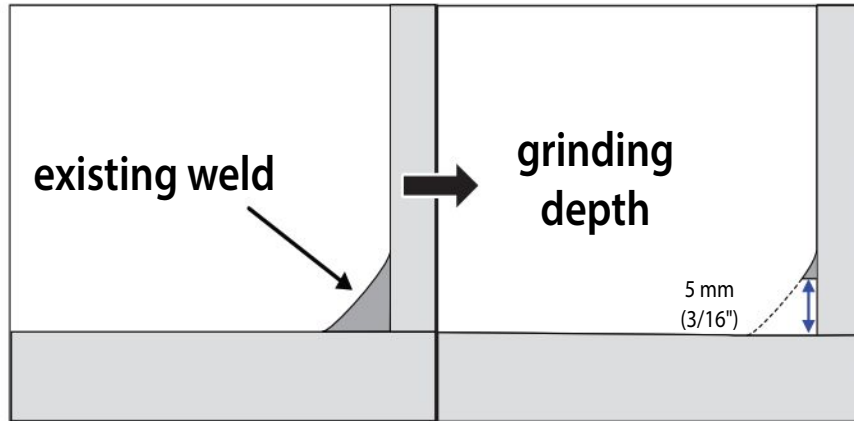

- Grind to 50 mm to 50.5 mm (1.968" to 1.988") in from the rear edge.
- Continue around the corner.
- Grind along the left side for a length of 50 mm (1.969").
- Grind in from the left edge 55 mm to 55.5 mm (2.165" to 2.185").

**Grind 2:** Do the same on the right side.

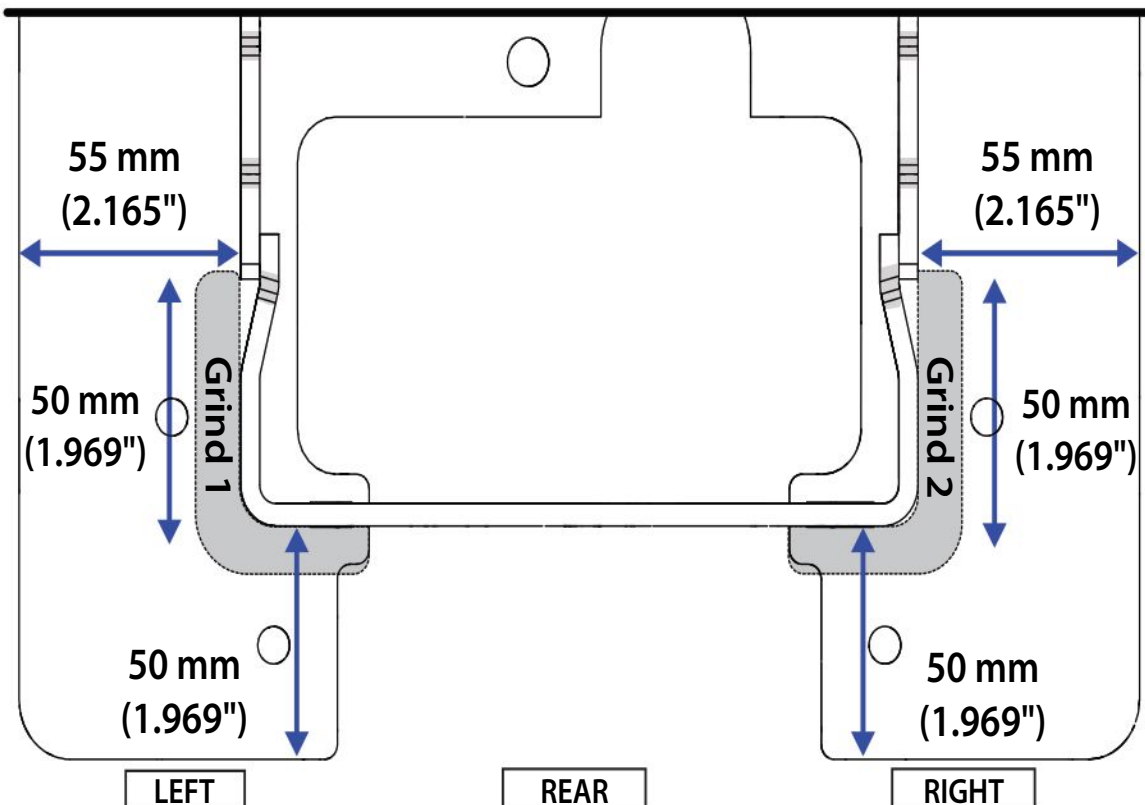

**Weld 5:** Weld along the outer rear left corner of the mast, starting just behind the vertical seam, welding toward the opening.

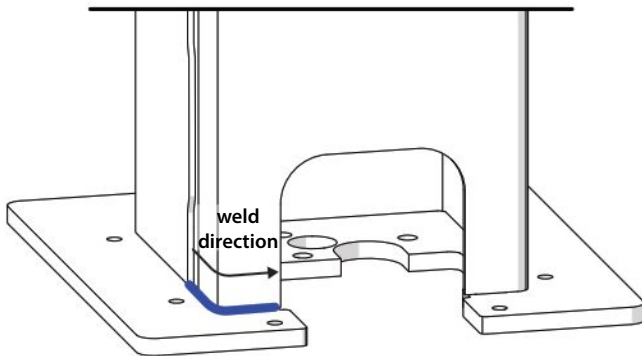

**Weld 6:** Weld along the outer rear right corner of the mast, starting just behind the vertical seam, welding toward the opening.

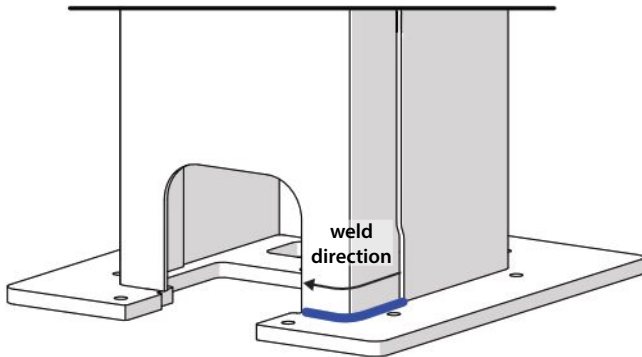

Clean up debris or spatter on the mounting surface inside the mast when the welding is done. See the affected area below.

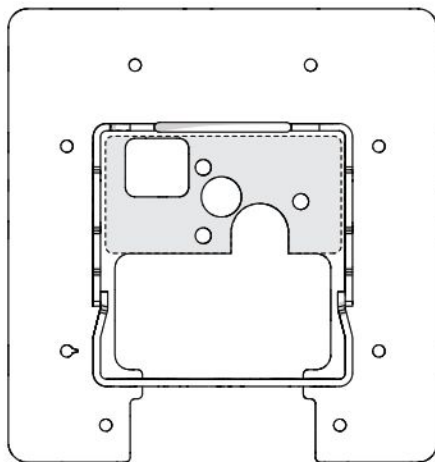

## 2.3 Touch up the paint

1. Remove damaged or flaking paint, including on the underside of the mast foot.
2. Apply black paint to the foot of the mast (top and bottom), and in a 10 cm (4") tall band around the mast, inside and out. Allow the paint to dry completely.
3. Tap the threaded holes to remove paint.

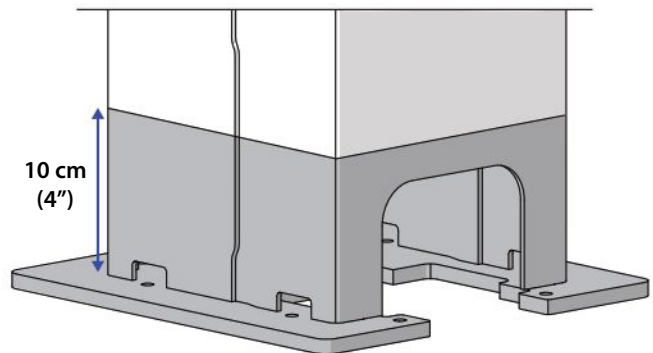

4. Take the dry mast back to the assembly area and lay it horizontally on blocks or supports with the e-lowering cutout facing down.

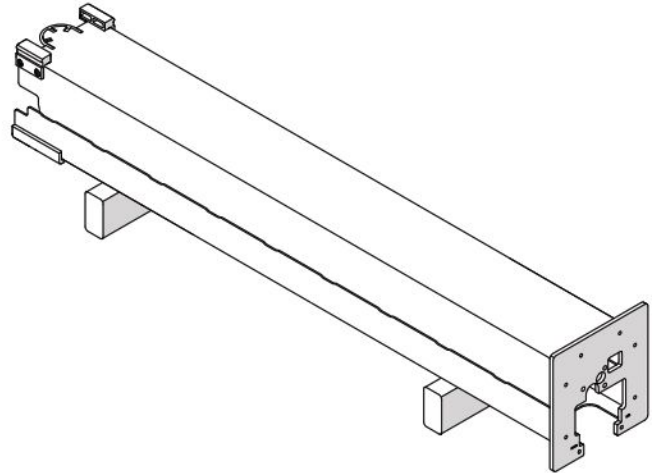



## 2.4 Install the mast, base cover, and platform

### 2.4-1 Assemble the mast

1. Look down the inside of the main mast assembly. Check if the top of the inner cylinder and e-lowering manifold are straight.
2. If the manifold is twisted, straighten it. If the top of the inner cylinder is twisted, use some wooden blocks as wedges to hold it horizontal.

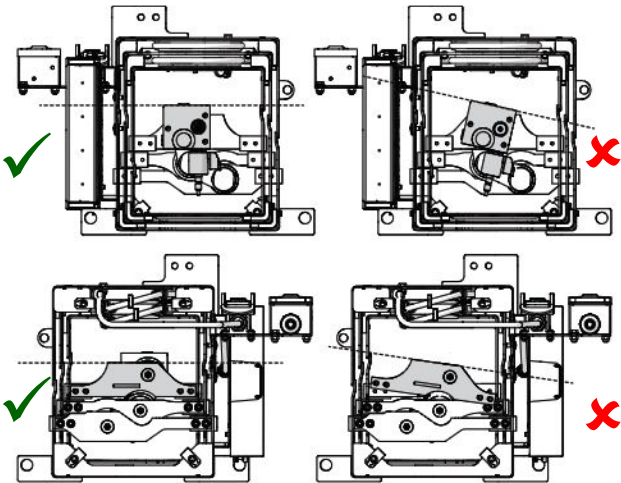

3. Slide the innermost mast about 2/3 of the way into the mast assembly.

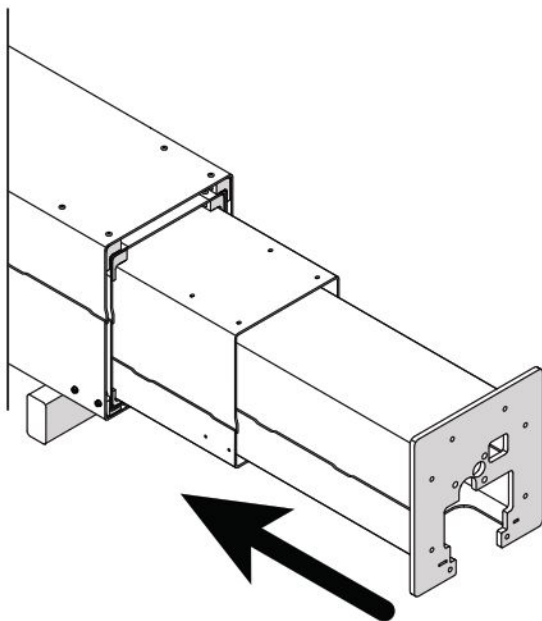

4. Take the mast control cable and power cable and feed a loop into the top of the mast, between the innermost and next mast.

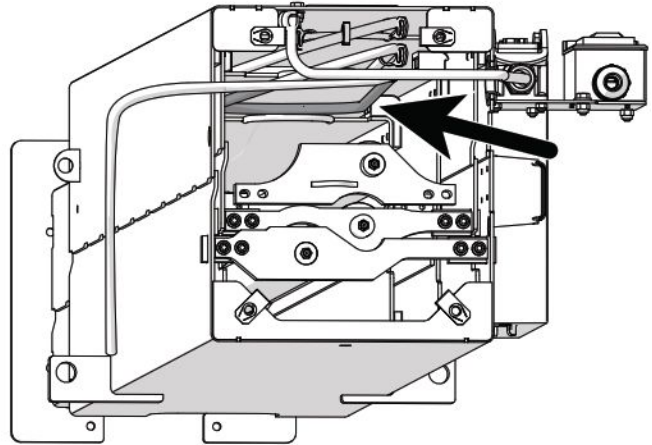

5. Be careful not to twist the cables, and use a long rod to push the cable loop down the mast until the loop appears from the bottom of the mast.

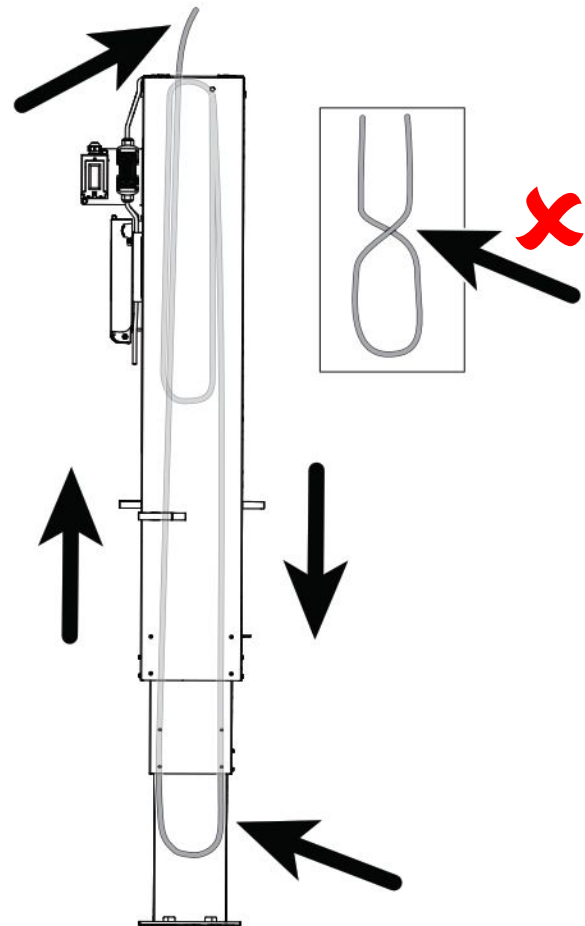



- 6. Place the loose cable weight in the loop.
- 7. Pull on the loose end of the cables at the top of the mast until the weight slides into the mast and is hidden from view.

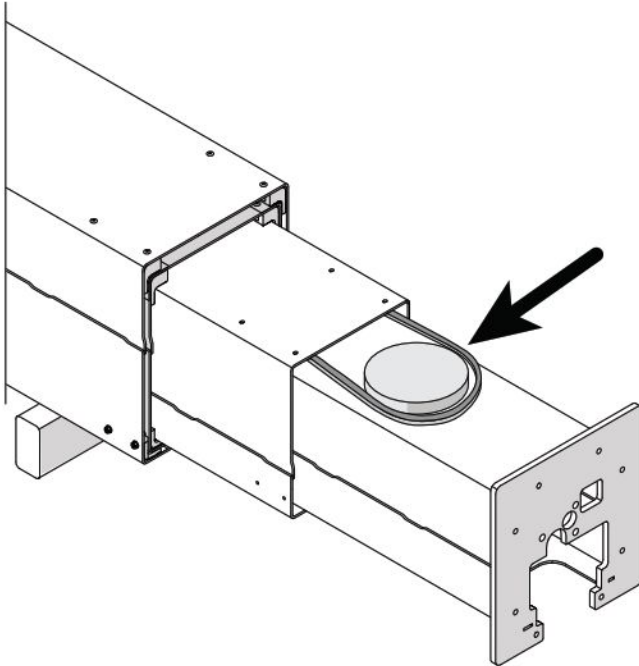

- 9. Secure the bottom two wear pads with the four screws removed earlier, and the top two with four rivets 5 mm x 14 mm (3/16" x 9/16").

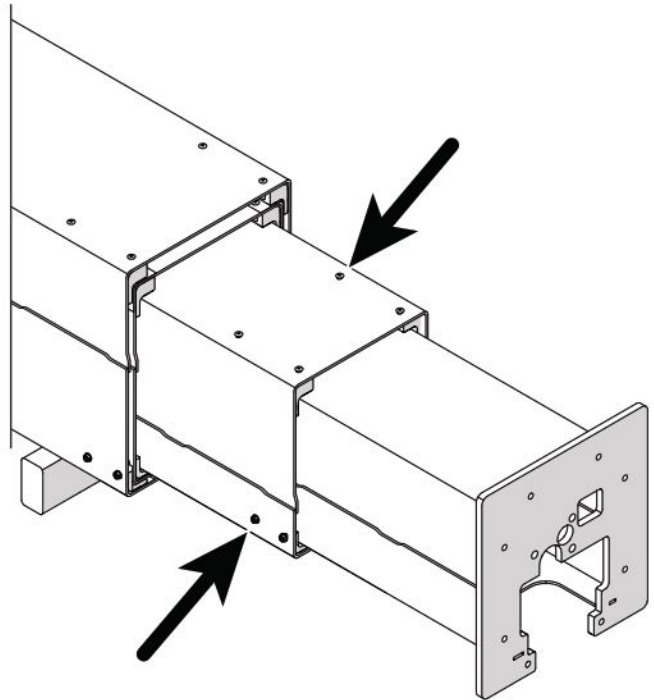

- 8. Put the four wear pads removed earlier into place on the mast.

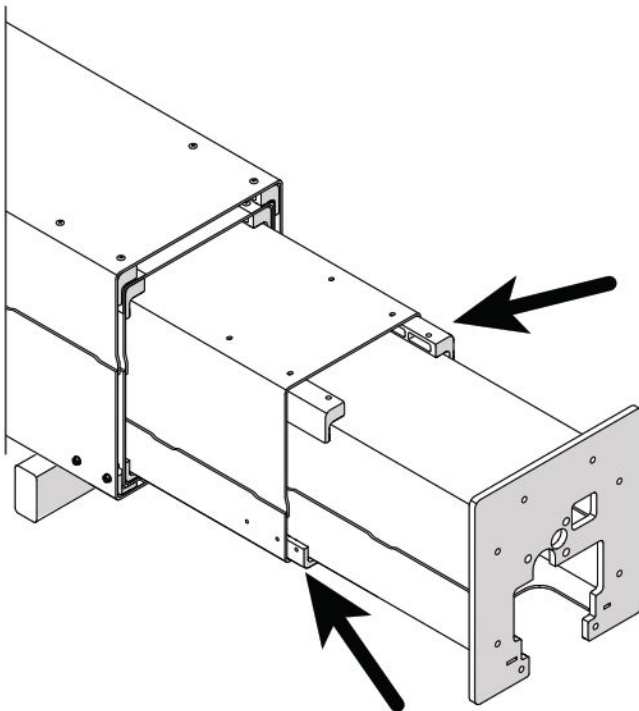

- 10. Push the innermost mast in almost all of the way. Centre the lift cylinder fitting in the hole in the bottom of the mast. Use wooden blocks or a prybar as needed to adjust the cylinder until the fitting is centered.

- 11. Push the mast in all of the way.

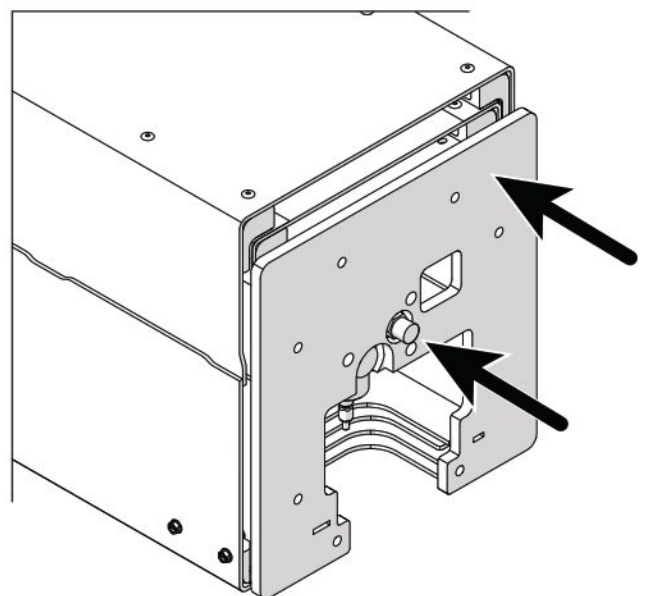

12. Apply medium-strength threadlocker to the three bolts removed earlier. Secure the bottom of the cylinder to the innermost mast with the bolts and washers. Torque the bolts to 31 Nm (23 ft-lb).

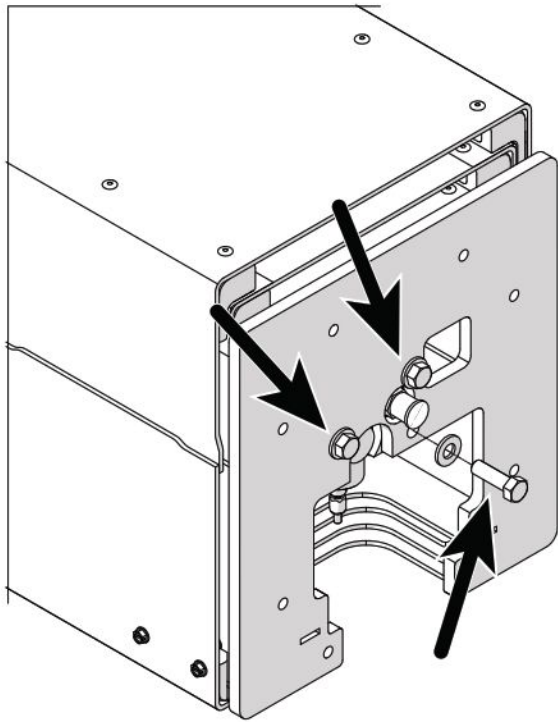

13. Apply medium-strength threadlocker to the four bolts earlier. Secure the top of the innermost cylinder to the mast with the bolts and washers. Torque the bolts to 8 Nm (75 in-lb).

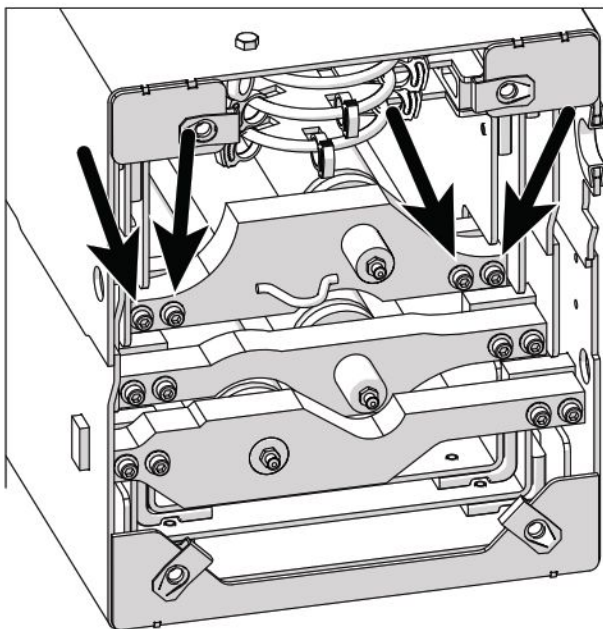

14. Install the nut and bolt you used earlier through all of the masts at the top. Tap on the bottom of the mast with a rubber mallet as needed to align the holes.

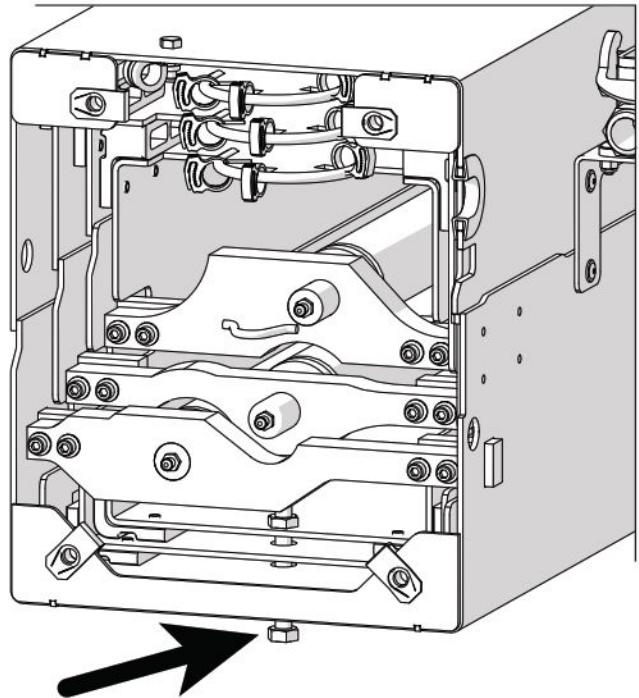

15. Line up the coloured band on the mast control and power cables with the top of the cable loop on the innermost mast.
16. Use the clips removed earlier or cable ties to secure the cables to the mast in three places.

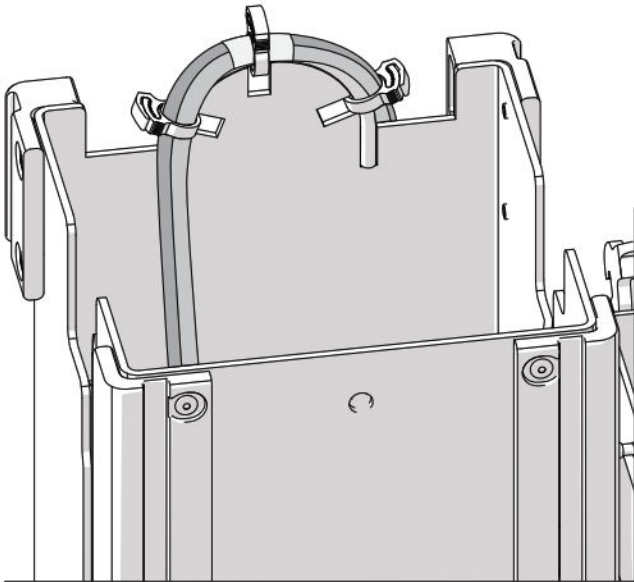
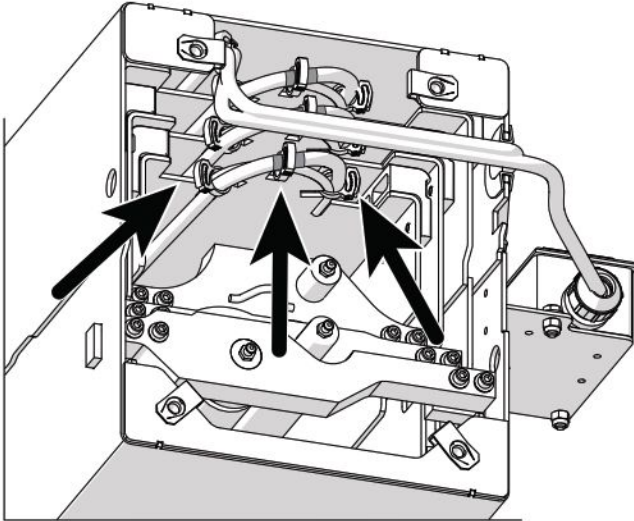

## 2.4-2 Install the mast

1. Connect a suitably rated lifting device to the top of the mast.
2. Lift the mast to a vertical position.

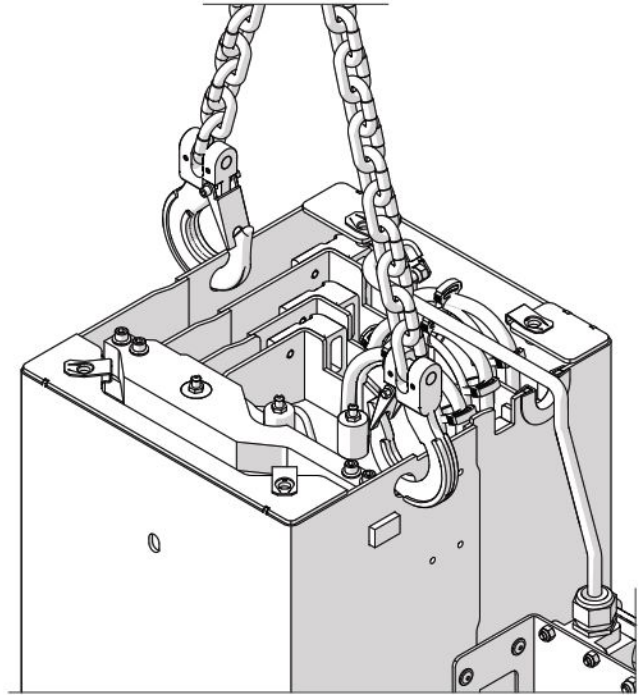

3. Place locating pins or bolts into the two mast mounting holes nearest the e-lowering cutout to help guide the mast into place.
4. Move the mast into place on the chassis.

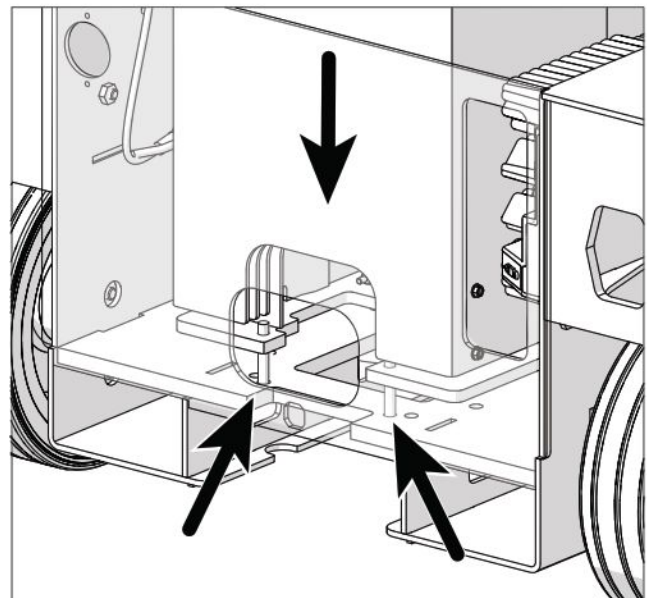

5. Remove the locating pins as you secure the mast to the chassis in eight places with the hardware removed earlier. Apply medium-strength threadlocker to the bolts before you install them. Torque them to 47 Nm (35 ft-lb).

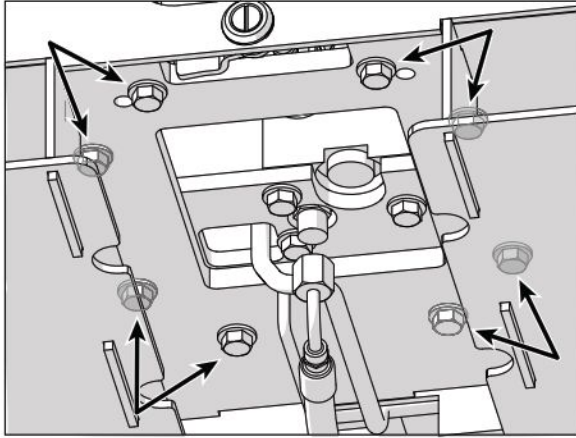

6. Connect the hydraulic hose to the lift cylinder. Torque the hose end to 25 Nm (18.5 ft-lb).

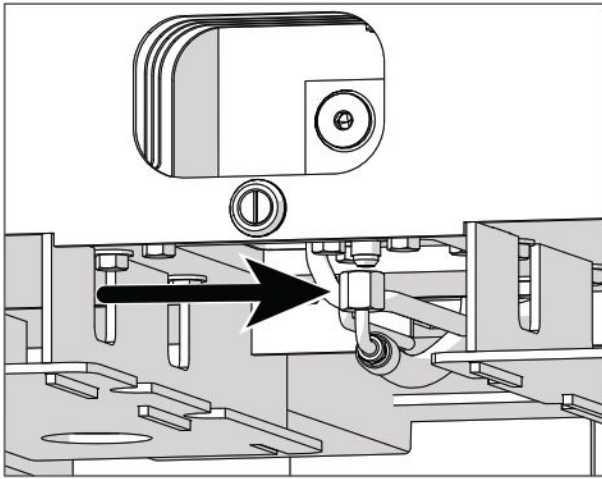

7. Insert the e-lowering valve into the cylinder manifold.

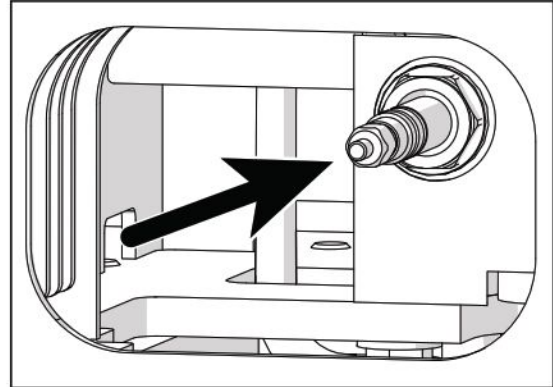

8. Place the coil on the valve and secure it with the coil nut.

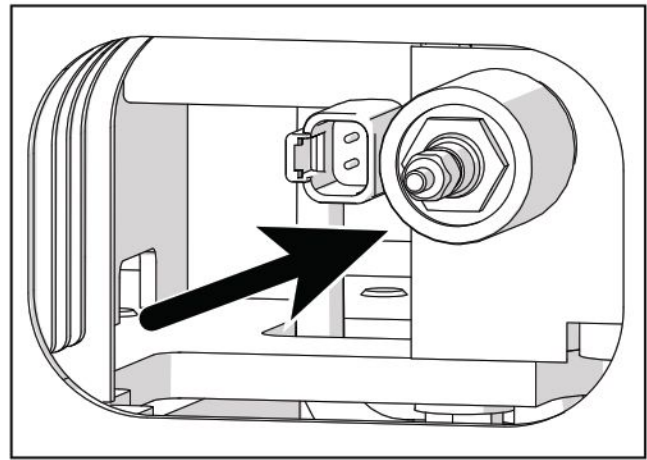

9. Connect the valve stem and knob to the valve.

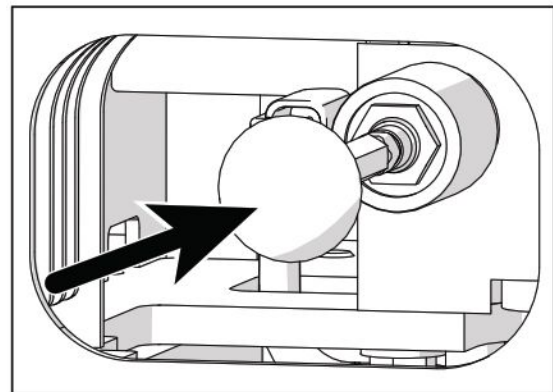



10. Connect the e-lowering valve harness.

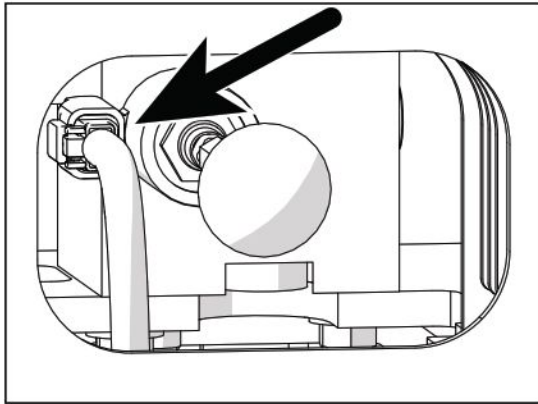

11. Insert the EcoTray, if equipped.

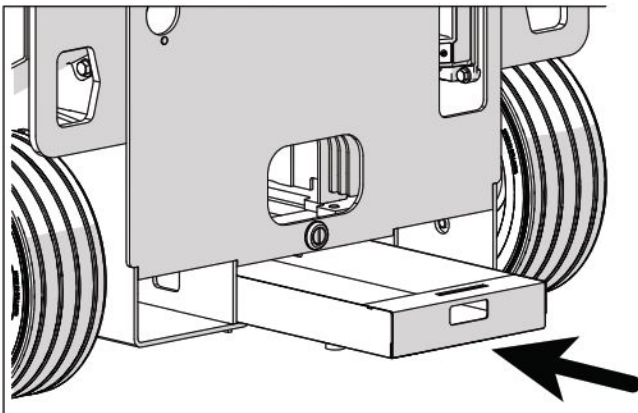

12. Remove the nut and bolt you installed earlier through all of the masts at the top.

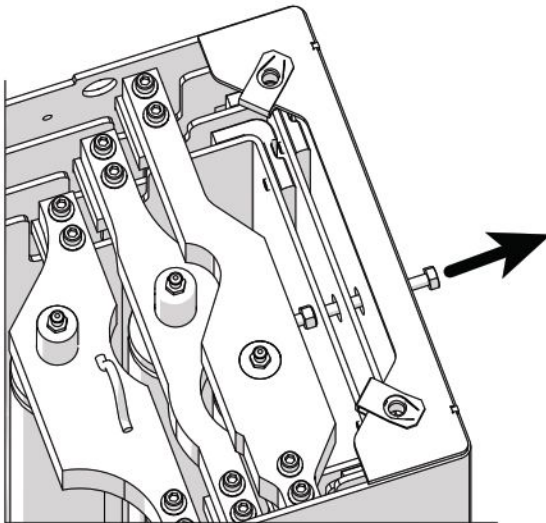

### 2.4-3 Base electrical connections

1. Feed the loose ends of the mast control and power cables down the mast and out the bottom through the cutout in the mast.

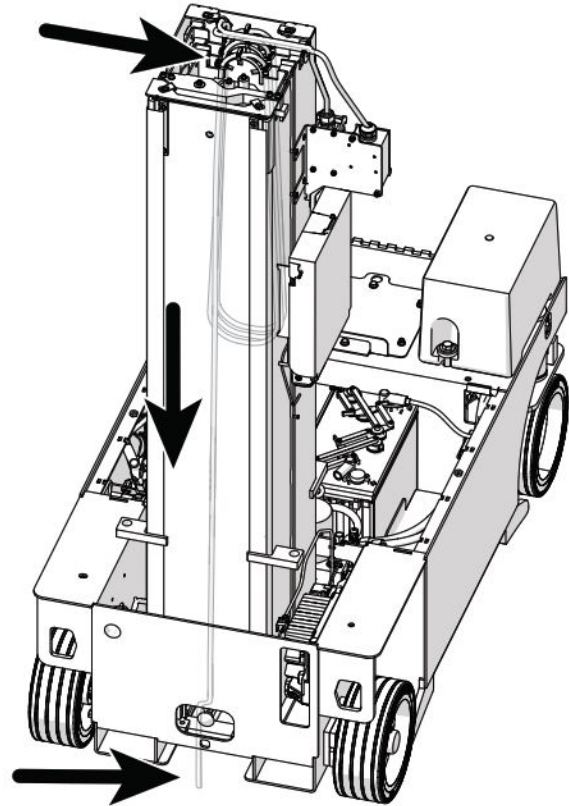

2. From the underside bring the cables through the cutout into the chassis.

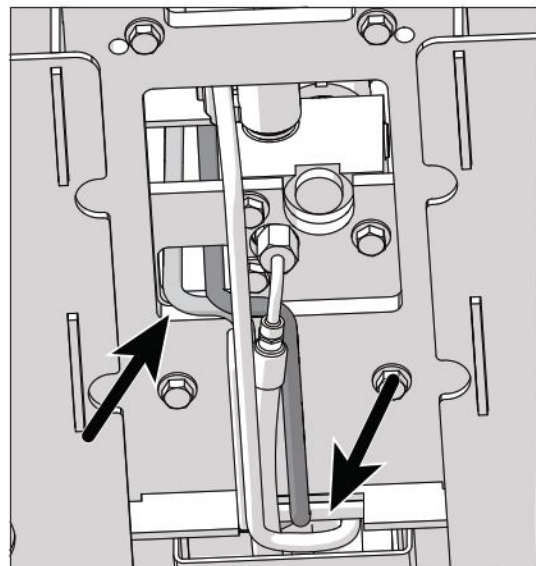

3. Bring the mast control cable out into the main chassis compartment. Connect the cable to the main harness.
4. Feed the power cable out of the AC plug mounting hole in the chassis.

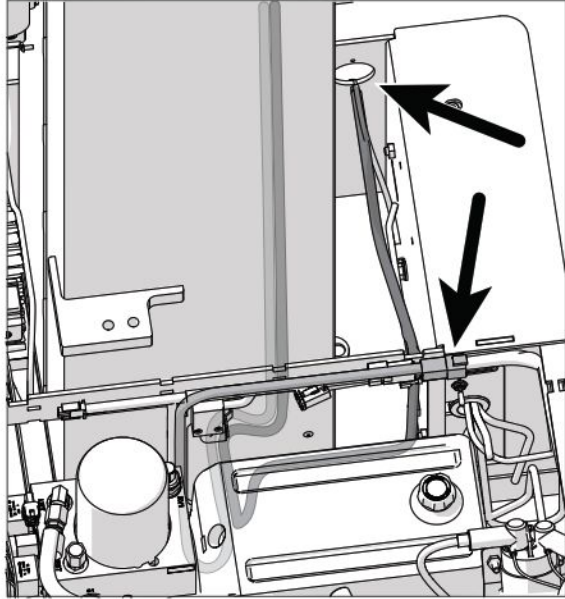

6. Secure the plug housing to the chassis with two rivets 4 mm x 8 mm (5/32" x 5/16").

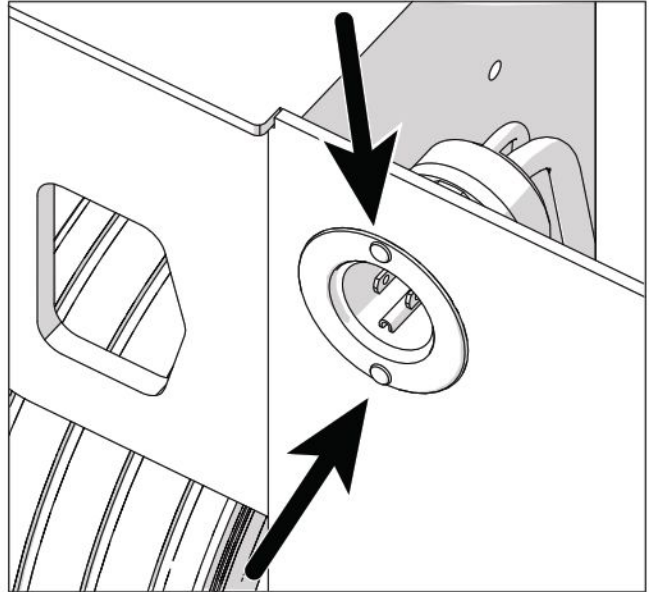

7. Use cable ties to secure the power cable to the cable carrier.

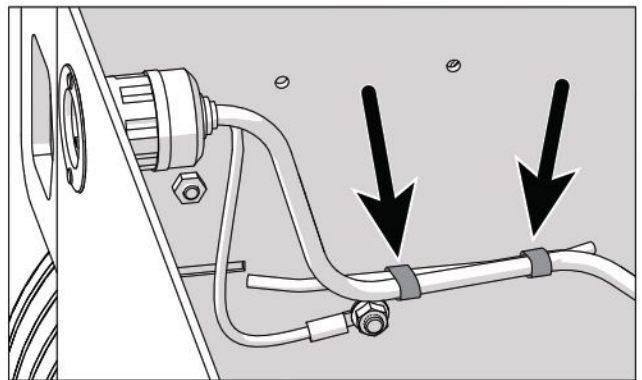

**Note:** the AC plug differs from region to region. The ANSI/CSA installation is shown below.

5. Feed the AC power cable and the green ground wire through the plug seal to the plug.
  - Connect the green wire to the green screw.
  - Connect the black wire to the gold screw.
  - Connect the white wire to the silver screw.

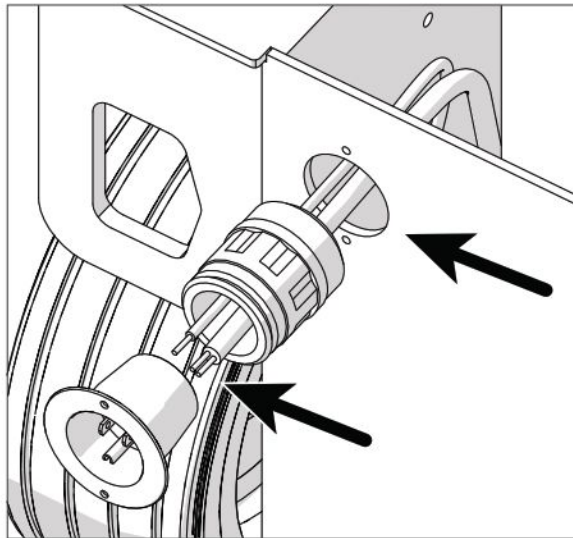

### 2.4-4 Install the base cover

1. Set the base cover in place, making sure you bring the charger cord out before setting the the cover down fully. Secure the cover with the hardware removed earlier.

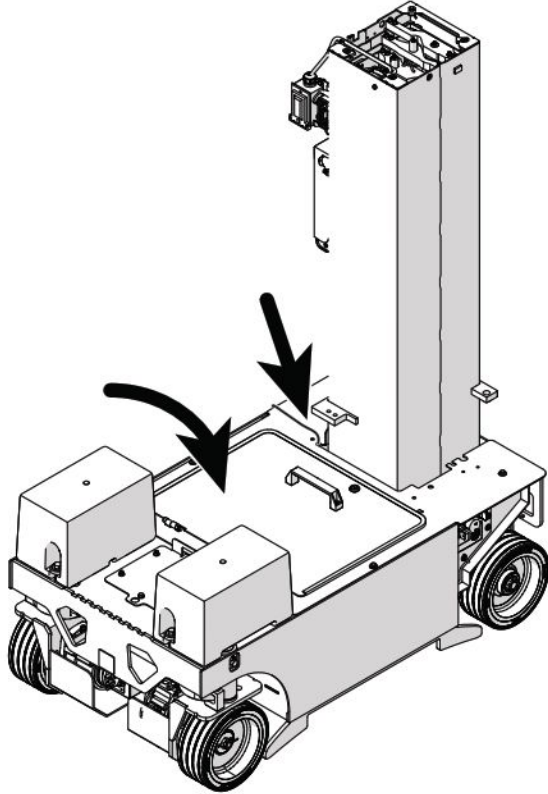

5. Place the charger cord in the grommet on the base cover. Secure the cord to the cover with two cable ties.

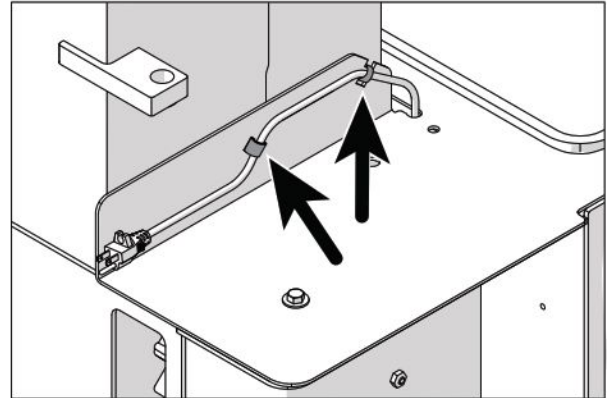

Next step:

### **IMPORTANT**

Handle the load cell module and load cells carefully as they are very easily damaged.

2. Open the base cover lid.
3. Reconnect the flashing light(s), white noise alarm, and Elevate keypad (if equipped). Secure the keypad to the bracket.
4. Use cable ties to secure all of the cables to the base cover as before.

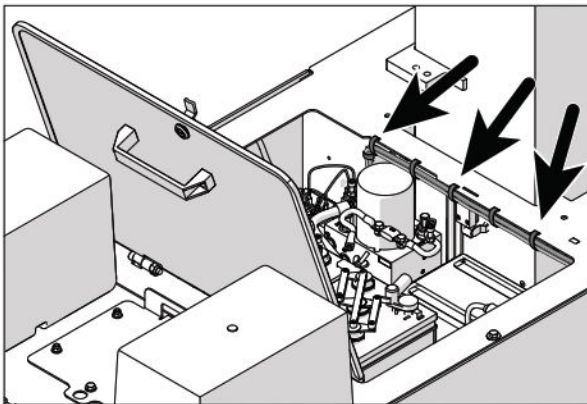



### 2.4-5 Install the platform

1. Install the load cells on the mast with the hardware removed earlier. Apply medium-strength threadlocker to the bolts before you install them, and torque them to 122 Nm (90 ft-lb).
2. Refer to the images below for the correct placement and orientation. The load cells are marked “RIGHT,” “LEFT,” and “FRONT.” Make sure they are installed in the correct positions, as shown below. Also make sure the load cells are installed with the arrows pointing down.

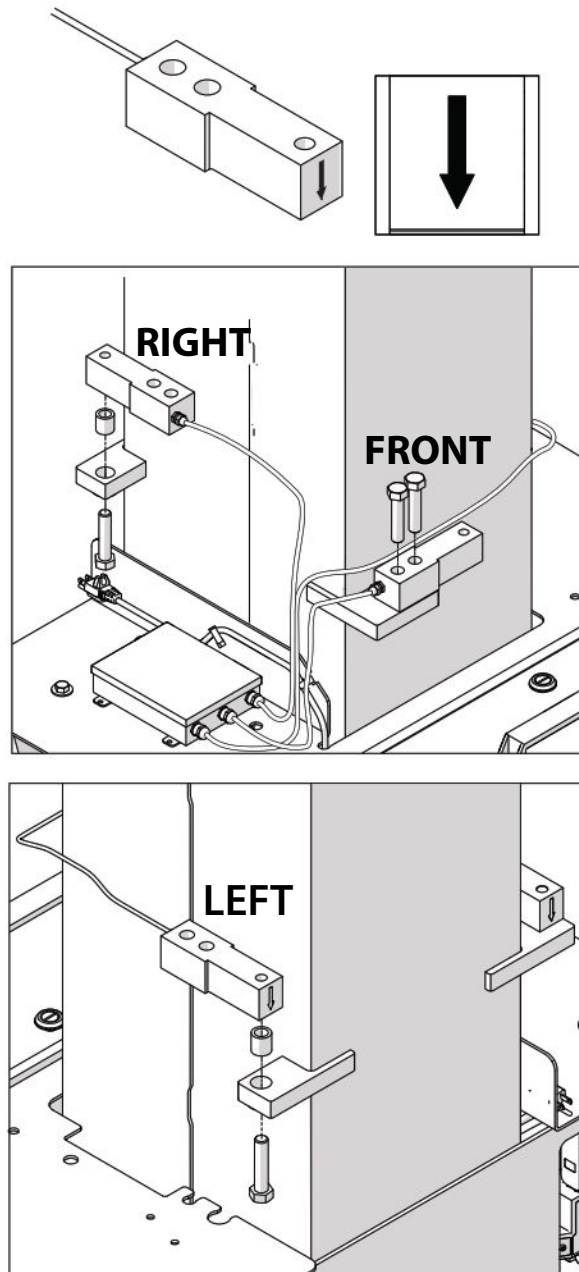

3. Apply medium-strength threadlocker to the bolt removed earlier. Secure the link weldment to the mast with the spacer, washer, and bolt. Torque the bolt to 122 Nm (90 ft-lb).

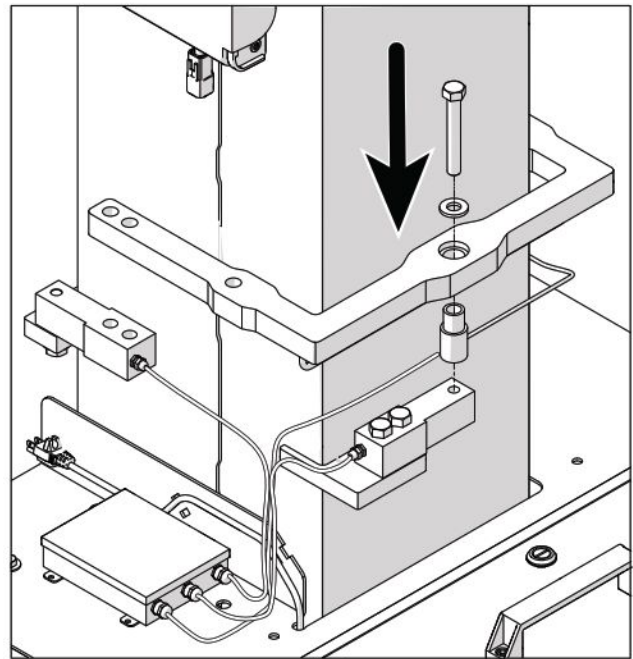

4. Use a suitably rated lifting device to lift the platform over the mast.

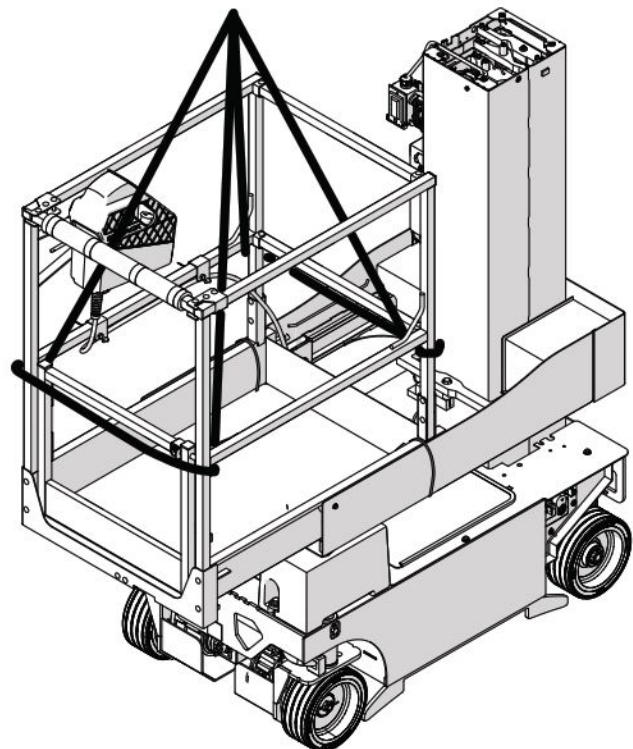



5. Secure the platform to the mast, load cells and link weldment with the six sets of hardware removed earlier. Apply medium-strength threadlocker to the bolts before you install them. Torque the bolts to 122 Nm (90 ft-lb).

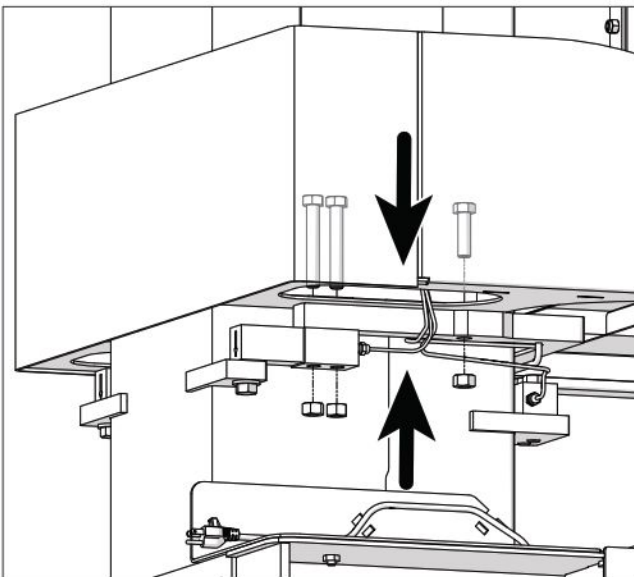
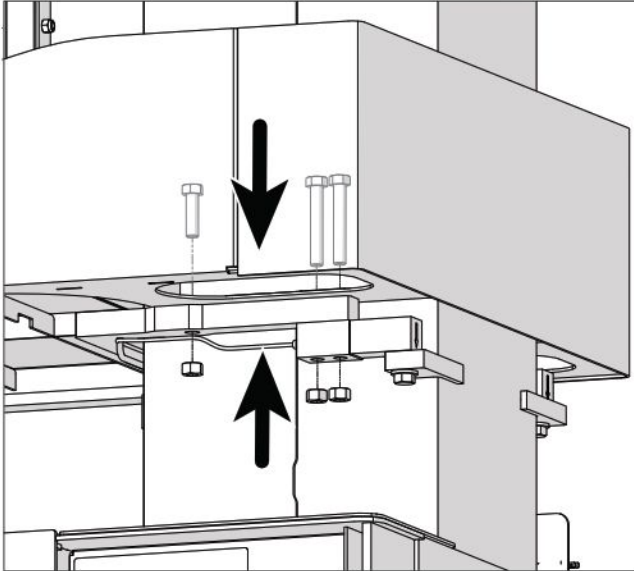

**IMPORTANT**

Handle the load cell module and load cells carefully as they are very easily damaged.

6. Attach the load cell module to the platform with the hardware removed earlier.

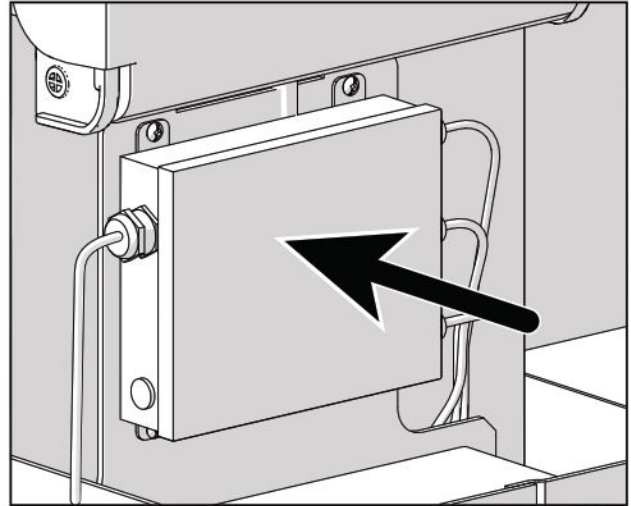

7. Connect the mast cable to the load cell module cable.
8. Use cable ties to bundle the load cell cables together neatly.

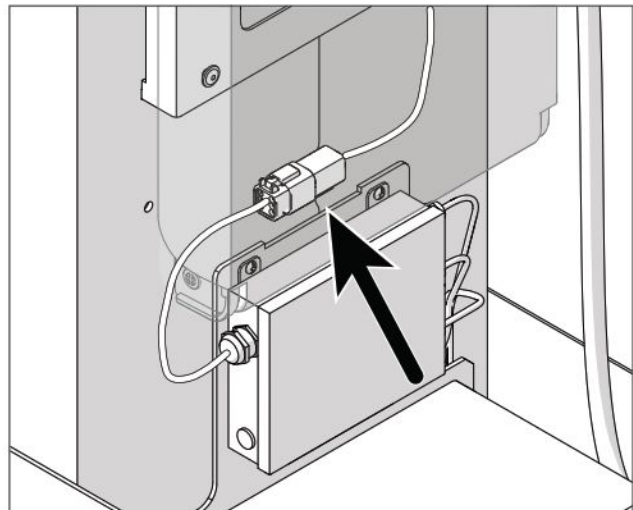

9. Insert the two platform limit switches into the mast electrical housing.
  - Connect the service position limit switch black wire 7 to position 7.
  - Connect the service position black/white wire spade connector to the purple/white wire spade connector on the deck extend limit switch.
  - Connect the deck extend limit switch black wire 6 to position 6.
  - Connect the deck extend limit switch black/white wire 5 to position 5.

10. Secure the socket to the housing.

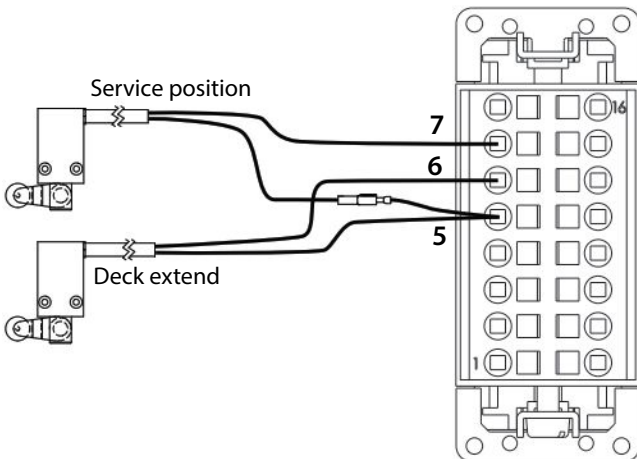
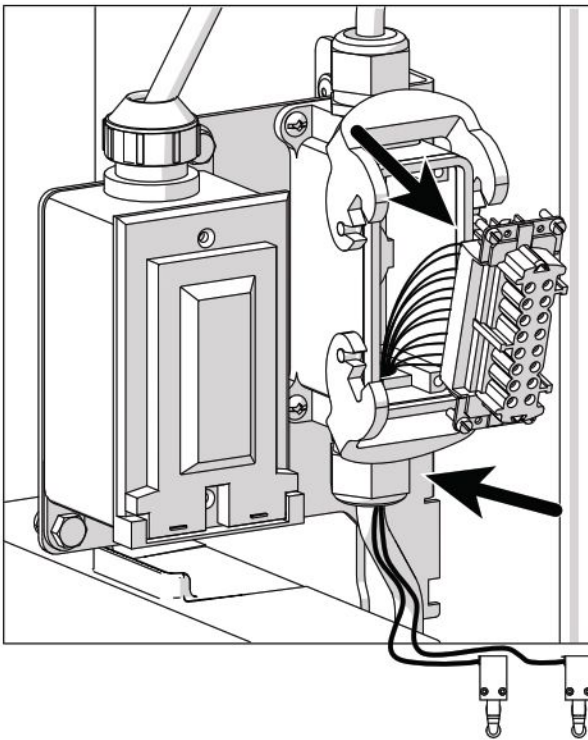

11. If your mast electrical connector mounts to the side of the mast, reattach it now.

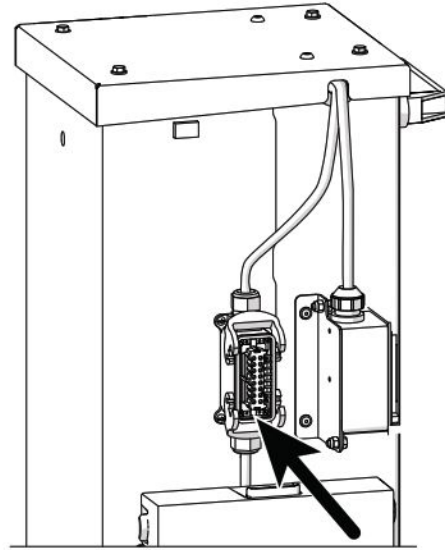

12. Connect the platform control box cable to the mast electrical connector.

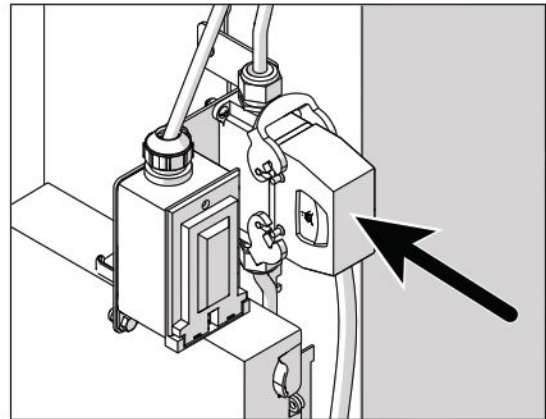

13. Install the mast cover.

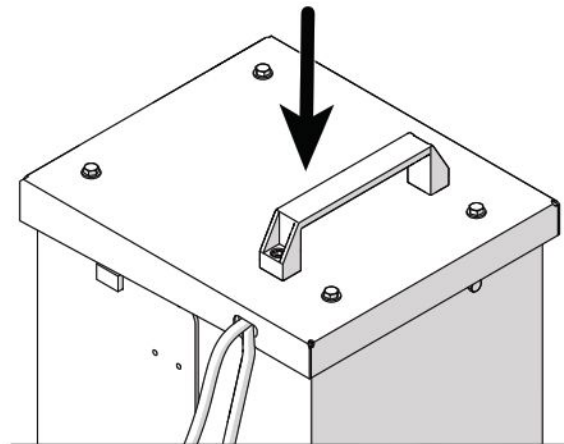

- 
14. Cut the two cable ties securing the platform deck.

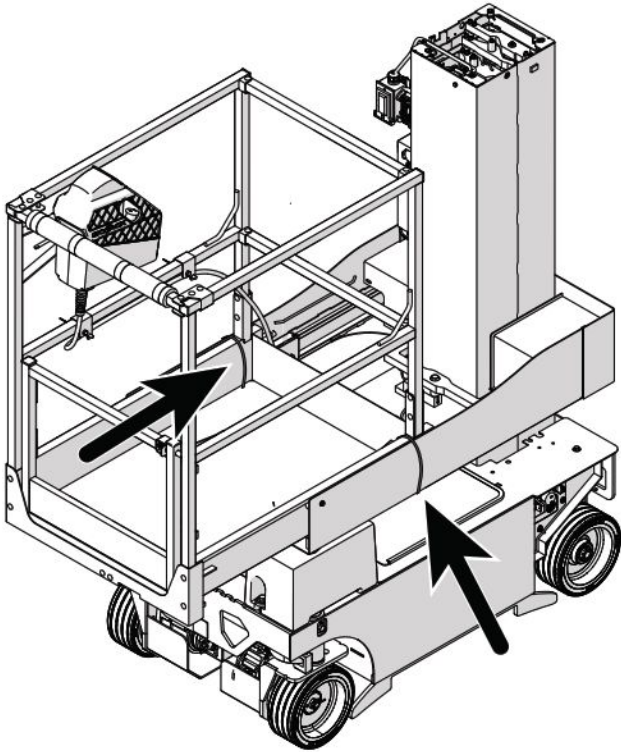

15. Slide the platform in all the way.

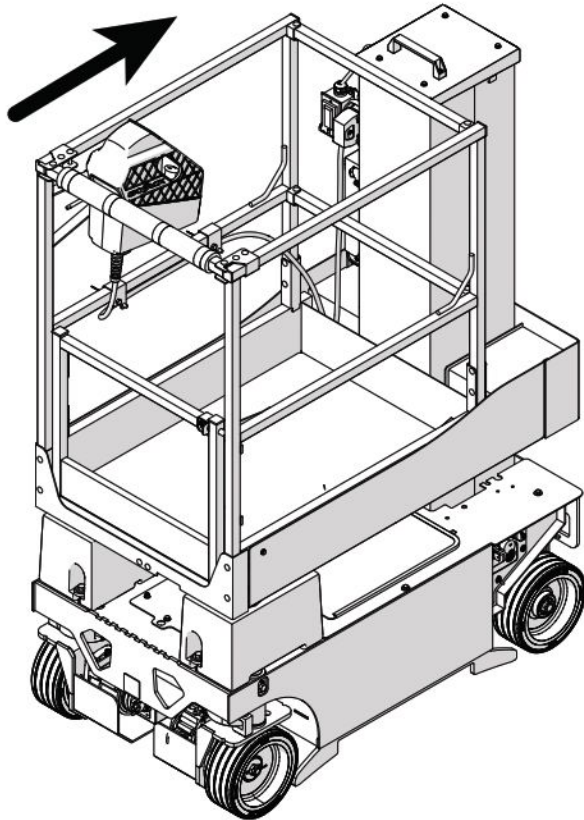

---

## Section 3 – Testing

1. Do all of the function tests given in your unit's operation manual.

**SKYJACK**<sup>™</sup>

[www.skyjack.com](http://www.skyjack.com)